

A modern bathroom vanity featuring a white rectangular sink set into a dark, possibly black, countertop. Above the sink, a dark planter box holds several green plants. The background wall is light-colored with large tiles. A logo for 'stern' is visible in the upper left. The overall aesthetic is clean and contemporary.

stern

THE GERM FREE AUTOMATED ENVIRONMENT  
**CATALOGUE**

# DISCOVER STERN'S TOUCHLESS WC CUBICLES



## ENHANCE RESTROOM EXPERIENCE WITH **TOUCHLESS WC CUBICLES** AND OCCUPANCY INDICATORS

- Optimizing Surface Hygiene and Minimizing the Risk of Cross Contamination
- Quick & Easy Installation
- Intuitive and Simple Use
- Safe and Reliable
- Minimal Maintenance and Failure-Free



## MINIMIZE CONTACT WITH SURFACES AS MUCH AS POSSIBLE

Since 1989, Stern - one of the pioneers in touchless sanitary products for public toilets – has been producing touchless faucets, soap dispensers, flush valves and hand dryers. But what about the contact applied to open the door of the WC cubicles?

Now you can ensure optimal surface hygiene and minimize the risk of cross-contamination using Stern's touchless bathroom cubicles.



For more details about Stern's touchless cubicles please contact:  
[info@sternfaucets.com](mailto:info@sternfaucets.com)

# WHY STERN?



Stern blends cutting-edge technological innovation, foresight, ease of use, and impeccable style, all in a single package. A world leader in the sanitary market for nearly 36 years, Stern develops and manufactures touchless faucets, automatic soap dispensers, flush valves, shower controls, and a multitude of related accessories.

Equipped with advanced technologies and machines run by a talented team of over 300 people, Stern creates an extensive product line for both commercial and residential installations. Every product at Stern is visionally conceived, practically engineered, and successfully launched to improve the user experience around the globe.

By marrying our market intuition with our technological know-how, we create electronic products that effectively and efficiently answer global needs in line with international standards and expectations. We remain wholeheartedly committed to green building and water-efficiency to help minimize the use of water and energy.

And as we produce everything in-house, we are able to adjust, combine, upgrade and resize to your hearts' desire, keeping Stern at the very forefront of world technology and design.

## STERN LEADS THE WAY

The Leadership in Energy and Environmental Design (LEED) is a certification developed by the USBCG (United States Green Building Council) – an organization dedicated to environmentally conscious construction. The LEED certification encourages sustainable building practices and promotes environmental preservation. Among the key issues measured by the organization are water and energy efficiency.

The certification is based on a points system, with a minimum of 2 points awarded for a 25% water usage reduction, with a maximum of 6 points for a 50% reduction. The USBCG applies its LEED certification points system to a wide variety of construction projects: commercial buildings, office buildings, schools, hospitals, hotels, and more.

With water conservation as one of our main goals, Stern has developed a line of products with extremely high water efficiency. Our products provide a minimum of 30% water reduction (worth 4 points) and up to to 58% water reduction (worth 6 points). Stern products are the best way for any construction project to achieve the highest score in the water efficiency category of the LEED certificate.

Stern products and LEED points

SOURCE: LEED V4.1, UPDATED: JANUARY 2022

Commercial Fixtures, Fittings, and Appliances	LEED Baseline (IP Units)	LEED Baseline (SI units)	Stern Best solutions (IP Units)	Stern Best solutions (SI Units)
Flush valves for toilets	1.6 gallons per flush (gpf)	6 liters per flush (lpf)	Single Flush: 1.28 gpf Average Dual Flush: 0.89 gpf	Single Flush: 4.8 lpf Average Dual Flush: 3.37 lpf
Flush valves for urinals	1.0 gpf	3.8 lpf	0.125 gpf	0.5 lpf
Public lavatory (restroom) faucets	0.5 gallons per minute (gpm) at 60 psi except private applications	1.9 liters per minute (lpm) at 415 kPa, except private applications	0.35 gpm at 50 psi	1.32 lpm at 350 kPa
Shower heads	2.5 gpm at 80 psi per shower stall	9.5 lpm at 550 kPa per shower stall	1.06 gpm at 50 psi per shower stall	4.0 lpm at 350 kPa per shower stall



**ALWAYS COMMITTED TO GREEN BUILDING AND WATER-EFFICIENT PRODUCTS**

# WHAT'S NEW?

## SWAR New Options

The newest version of SWAR has been fitted with a concealed screen for broadcasting news and advertising, to be viewed while users wash, soap and dry their hands in your commercial washroom. The lockable mirror conceals the screen completely and the tablet is only visible when needed, creating a sophisticated approach to elegant advertising.

Page 83



## Boreal Faucet & Soap Dispenser

Water & soap come together, perfectly matched, with this stellar looking pair. Sharp contours and straight lines infuse this minimalistic square design with a futuristic charm.

Page 8, 52



## Stern Trio

Complete solution for hand washing and drying. Eliminate those messy, slippery floors with Stern's all-in-one handwashing solution for either deck or wall-mounted designs.

Page 135

## Recessed Duo

The Recessed Mounting Duo is our concealed soap-water modular system in a Stainless Steel box for integration inside the wall, concealed inside the wall and behind a mirror or panel for the cleanest and most minimalistic design.

Page 88



## Csaba 2 in 1

Csaba 2-in-1, a touch-free deck-mounted electronic faucet and soap dispenser duo in a single unit, is ideal for retrofit projects where drilling a new basin opening is not possible.

Page 6

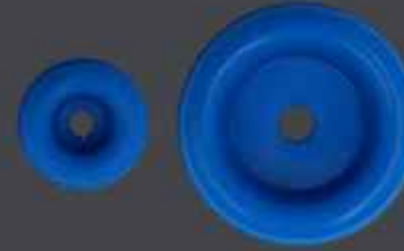

## Proprietary Soap Adaptor kits

Fully committed to your soap supplier but want to enjoy the ease, comfort and sustainability offered by Stern's touch-free soap dispensers? Fret no more! We have the ultimate solution for you to continue using your proprietary soap: Stern's Proprietary Soap Adaptors.

Page 77, 146



## Easy Refills

Lotus Top fill 2 liters container is easy to refill with your choice of hand soap. Our new touch-free deck-mounted soap dispenser's body is made of 100% Chrome plated brass, including the smart cap that allows to refill from the top.

Page 53



## Smartbox

Our Smartbox touch-free electronic hand sanitizer dispenser for wall-mounted installations is ideal for refurbishment projects.

Page 78



## Cool TF

Long and slender, Cool TF is perfectly curved to serve. Ideal for filling bottles in public washrooms to help conserve water while limiting the spread of germs and bacteria.

Page 26



## Csaba Petite Set

Petite and just the right size, our Csaba Petite Set is the ideal choice for spaces that require elegant subtlety and an air of refined sophistication.

Page 7, 49

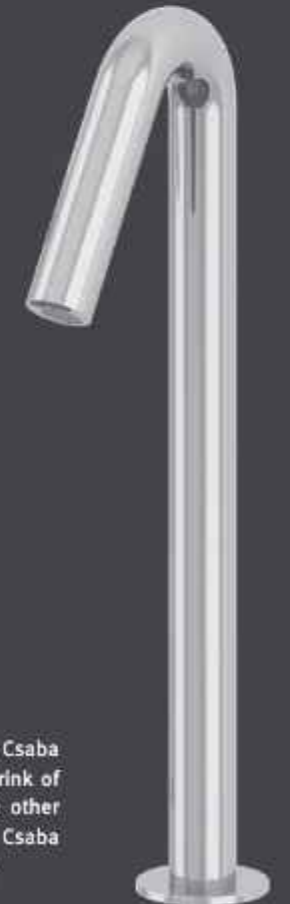

## Csaba Plus

Take your spirits higher with our newest Csaba model Csaba Plus, for a taller, loftier drink of water. About 1.5 times longer than the other Csaba counter top washbasin models, Csaba Plus raises handwashing to new heights.

Page 7

Before Choosing A New Faucet,  
**THINK FINISH FIRST**

New technology and an increasing appreciation for purposeful design in public bathrooms have made the faucet an important feature in bathroom decor.



**STAINLESS STEEL AISI 316**

Stainless steel faucets do not need finishing. The material itself is the finish and it offers corrosion resistance, formability, strength and easy maintenance. Combining elegant design with vandal resistant features, now more resilient than ever, our Stainless Steel AISI 316 series is long lasting even under the harshest conditions.



**POLISHED CHROME**

Resistant to rust and corrosion, Chrome is both cost-effective and easy to clean.

The graceful Chrome-plated finish is created through electroplating, which applies a liquid metal coating through electro deposition. As the deposited metal fuses to the base material, the refined and durable finish created is Stern's collection default.



**MATTE BLACK**

Powder coating is a finishing process in which a coating is applied electrostatically to a surface as a dry powder before heat is used to finalize the coating. The powder forms chemical bonds in the process creating a flexible, durable finish that is highly resistant to corrosion, flaking and scratching.

Exceptionally versatile and easy to clean, powder coating does not show dirt, water spots, or fingerprints.

**PVD COATING**

PVD coating (physical vapor deposition) is the process in which a solid material is vaporized in a vacuum and deposited onto the surface of the fixture. These compound materials are deposited atom by atom, forming a thin, bonded, metal surface layer that greatly improves appearance and durability.

Selected products are available in a variety of special finishes:



**PVD BRUSHED NICKEL**

Popular for its "stainless steel" appearance, PVD Brushed Nickel creates a sophisticated and cool look that hides fingerprints and water spots.



**PVD COPPER**

A velvety effect that goes well with contemporary and industrial styles.



**PVD GUNMETAL**

Inspired by rifle barrels with a sheen that's not quite matte and not quite shiny, gunmetal faucets add an interesting touch to any design, particularly when paired with industrial elements.



**PVD ANTIQUE BRONZE**

Dramatic and striking, antique bronze lifts the ambiance with a touch of texture.



LAVATORY FAUCETS

1-28



WALL MOUNTED FAUCETS

29-44



SOAP DISPENSERS &  
HAND SANITIZERS

45-80



HAND DRYERS &  
BEHIND THE MIRROR PRODUCTS

83-94



SHOWERS

95-112



URINALS & TOILETS

113-132



IRON FRAME SETS

133-140



COMPONENTS & ACCESSORIES

141-150



## LAVATORY FAUCETS



CSABA 2-IN-1

6



TOUCH FREE

22



CSABA

7



TUBULAR DM

22



BOREAL

8



CLASSIC

23



TRENDY

9 - 12



EASY

24



EXTREME

13 - 15



SWAN

25



QUADRAT DM

16



CONDOR

26



ELITE

17 - 18



DOLPHIN

27



SMART

19 - 20



COOL TF

28



GREEN

21

**ROUNDED EDGES AND  
SMOOTH TRANSITIONS**

**OPTIONAL SOAP LEVEL  
INDICATOR**  
ABOVE THE DECK

**CONCEALED SENSORS  
BUILT INTO THE SPOUT**

**EASY INSTALLATION**

**SENSOR SETTINGS ADJUSTABLE**  
BY REMOTE CONTROL

**IDEALLY SUITED FOR  
RETROFIT PROJECTS**

**NO PHYSICAL CONTACT**  
HELPS TO PROTECT USERS  
AGAINST CROSS CONTAMINATION





## CSABA SERIES

### Electronic lavatory faucet operated by IR sensor

Series includes options for cold or premixed water as well as hot and cold water. Activated by concealed IR sensor built into the spout.

IP67 dual power input box that allows the faucet to be used with 9V battery and can be powered by a 9V transformer which includes an integrated back up system to be used with a 9V lithium battery enabling the faucet to be used normally in case of power failure.

WATER SAVING OPTIONS		
1.89 LPM	0.5 GPM	PCA Spray
1.3 LPM	0.35 GPM	PCA Spray
4 LPM	1.0 GPM	PCA Spray



### NEW SIZE

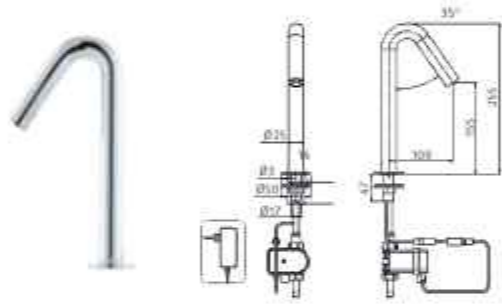

#### CSABA

- 233000 CSABA B, 9V Battery
- 233010 CSABA E, 9V Transformer

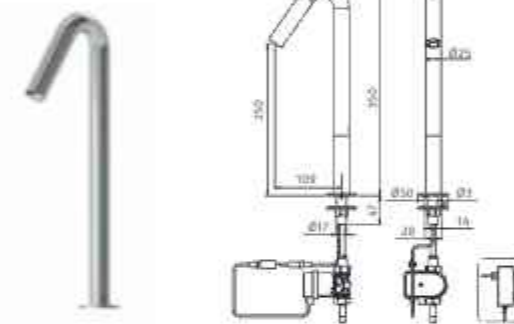

#### CSABA PLUS

Tall version

- 233050 CSABA PLUS B, 9V Battery
- 233051 CSABA PLUS E, 9V Transformer

### NEW SIZE



#### CSABA 1000

Mixer to adjust water temperature

- 233020 CSABA 1000 B, 9V Battery
- 233030 CSABA 1000 E, 9V Transformer

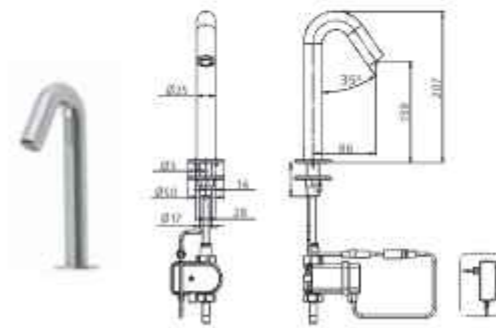

#### CSABA PETITE

Petite version

- 233042 CSABA PETITE B, 9V Battery
- 233040 CSABA PETITE E, 9V Transformer

## NEW!

## BOREAL SERIES

### Electronic lavatory faucet operated by IR sensor

Series includes options for cold or premixed water as well as hot and cold water.

WATER SAVING OPTIONS		
6 LPM	1.58 GPM	SSR PCA Stream
4 LPM	1 GPM	PCA Spray
3 LPM	0.8 GPM	PCA Spray
1.89 LPM	0.5 GPM	PCA Spray
1.3 LPM	0.35 GPM	PCA Spray

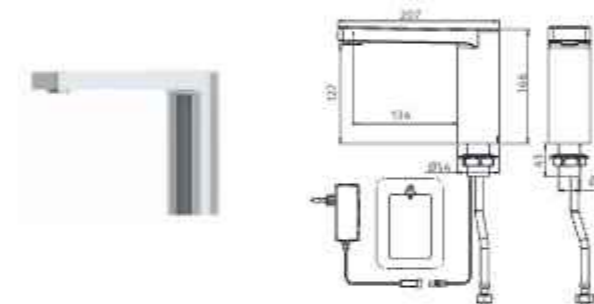

#### BOREAL

- 212000 BOREAL B, 6 X 1.5V AA batteries
- 212005 BOREAL E, 9V Transformer

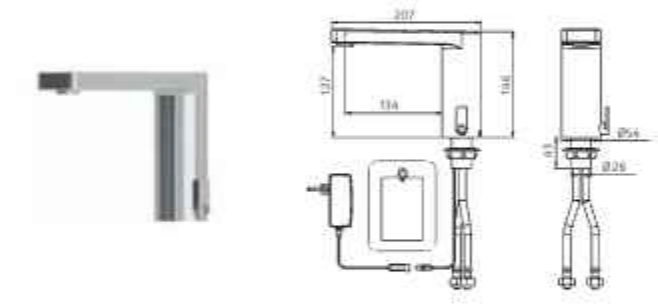

#### BOREAL 1000

- 212050 BOREAL 1000 B, 6 X 1.5V AA batteries
- 212055 BOREAL 1000 E, 9V Transformer

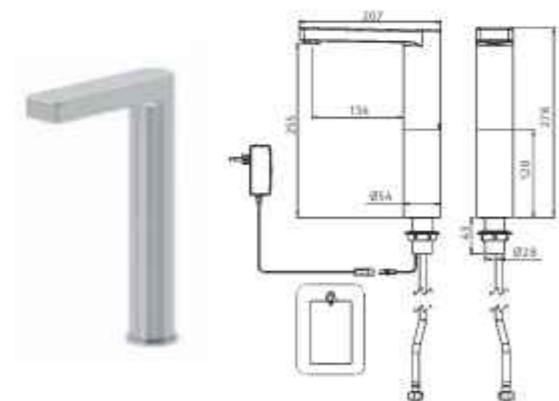

#### BOREAL PLUS

- 212010 BOREAL PLUS B, 6 X 1.5V AA batteries
- 212015 BOREAL PLUS E, 9V Transformer

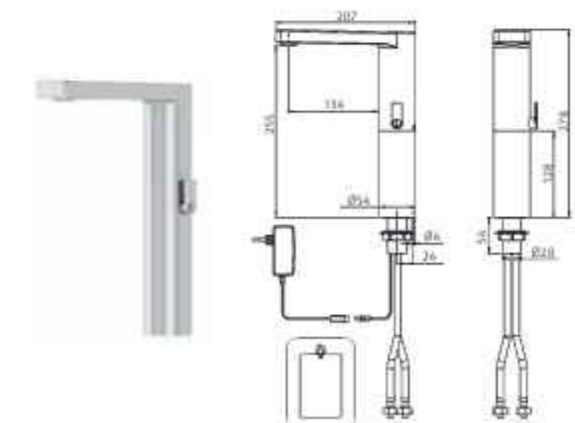

#### BOREAL 1000 PLUS

- 212060 BOREAL 1000 PLUS B, 6 X 1.5V AA batteries
- 212065 BOREAL 1000 PLUS E, 9V Transformer

# TRENDY SERIES

## Electronic lavatory faucet operated by IR sensor

Series includes options for cold or premixed water as well as hot and cold water, long spout, tall versions for counter top sinks and ring illumination models.

Furthermore, this series includes a solenoid valve, located inside the product, which makes it more resistant to vandalism.



WATER SAVING OPTIONS		
6 LPM	1.58 GPM	SSR PCA Stream
4 LPM	1 GPM	PCA Spray
3 LPM	0.8 GPM	PCA Spray
1.89 LPM	0.5 GPM	PCA Spray
1.3 LPM	0.35 GPM	PCA Spray

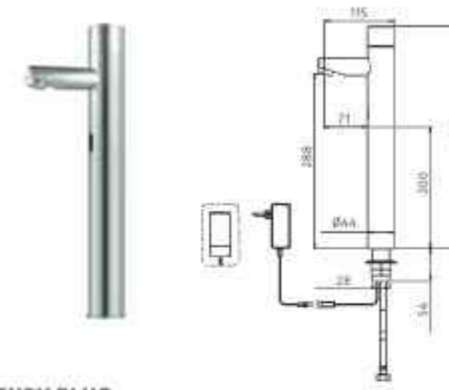

### TRENDY PLUS

Tall version for counter top wash basins

- 239050 TRENDY PLUS B, 9V Battery
- 239150 TRENDY PLUS E, 9V Transformer

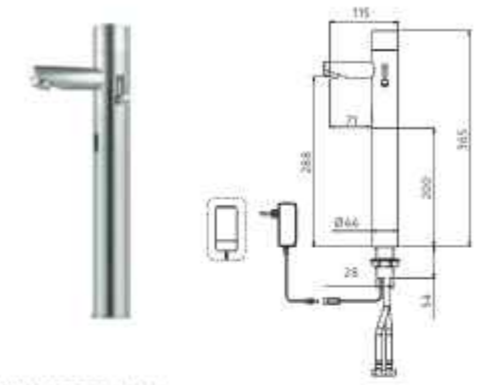

### TRENDY 1000 PLUS

Tall version for counter top wash basins

Mixer to adjust water temperature

- 239250 TRENDY 1000 PLUS B, 9V Battery
- 239350 TRENDY 1000 PLUS E, 9V Transformer

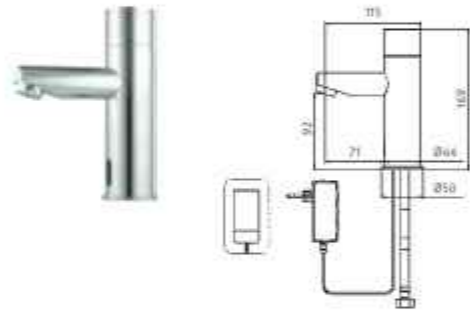

### TRENDY

- 239000 TRENDY B, 9V Battery
- 239100 TRENDY E, 9V Transformer

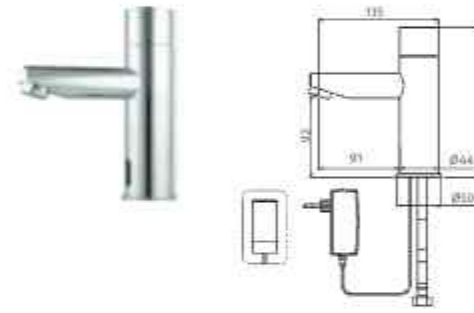

### TRENDY L

Long spout 90mm

- 239400 TRENDY LB, 9V Battery
- 239500 TRENDY LE, 9V Transformer



### TRENDY BRE

Permanent ring illumination. When a user places his hands within the sensor range, the ring of light blinks while water flows from the faucet.

- 239105 TRENDY BRE, 9V Transformer

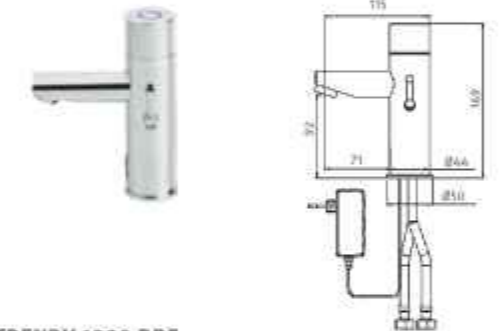

### TRENDY 1000 BRE

Mixer to adjust water temperature

Permanent ring illumination. When a user places his hands within the sensor range, the ring of light blinks while water flows from the faucet.

- 239305 TRENDY 1000 BRE, 9V Transformer

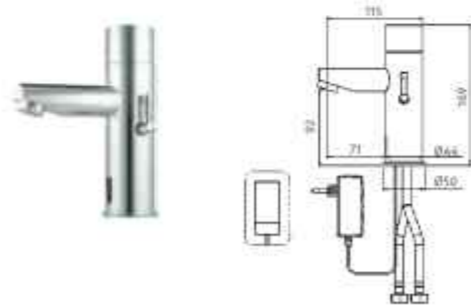

### TRENDY 1000

Mixer to adjust water temperature

- 239200 TRENDY 1000 B, 9V Battery
- 239300 TRENDY 1000 E, 9V Transformer

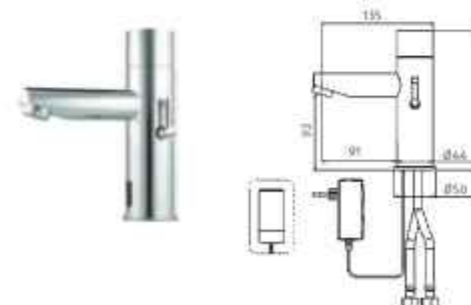

### TRENDY 1000 L

Mixer to adjust water temperature

Long spout 90mm

- 239600 TRENDY 1000 LB, 9V Battery
- 239700 TRENDY 1000 LE, 9V Transformer



# TRENDY T SERIES

## Electronic lavatory faucet operated by IR sensor

Features an integrated thermostatic mixer for an anti scalding operation and temperature control.

Trendy T ensures the water is temperature-balanced and helps prevent users from burning their hands.

### Additional Advantages:

- Lead free
- Thermostatic control for optimal temperature
- Including an internal comfort stopper that allows you to set the maximum temperature according to your preference
- Ideal for the healthcare sector
- Internal solenoid valve



### TEMPERATURE FEATURES

**HOT LIMIT STOPPER** - Mechanical mechanism for built in maximum temperature control at 48.9°C (120°F), factory set. Other values available upon request

**COMFORT STOP** - Option to limit the hot water temperature from 38°C (100.4°F) to 48.9°C (120°F).

**FIXED TEMPERATURE** - Allows the technical staff to set a consistent temperature and fix the faucet cap to a specific temperature.

WATER SAVING OPTIONS		
6 LPM	1.58 GPM	SSR PCA Stream
4 LPM	1 GPM	PCA Spray
3 LPM	0.8 GPM	PCA Spray
1.89 LPM	0.5 GPM	PCA Spray
1.3 LPM	0.35 GPM	PCA Spray

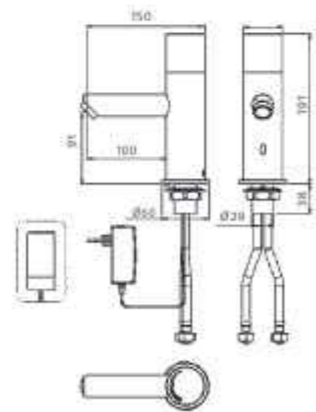

### TRENDY T

Integrated thermostatic mixer to adjust water temperature

- 236930 TRENDY TB, 9V Battery
- 236935 TRENDY TE, 9V Transformer

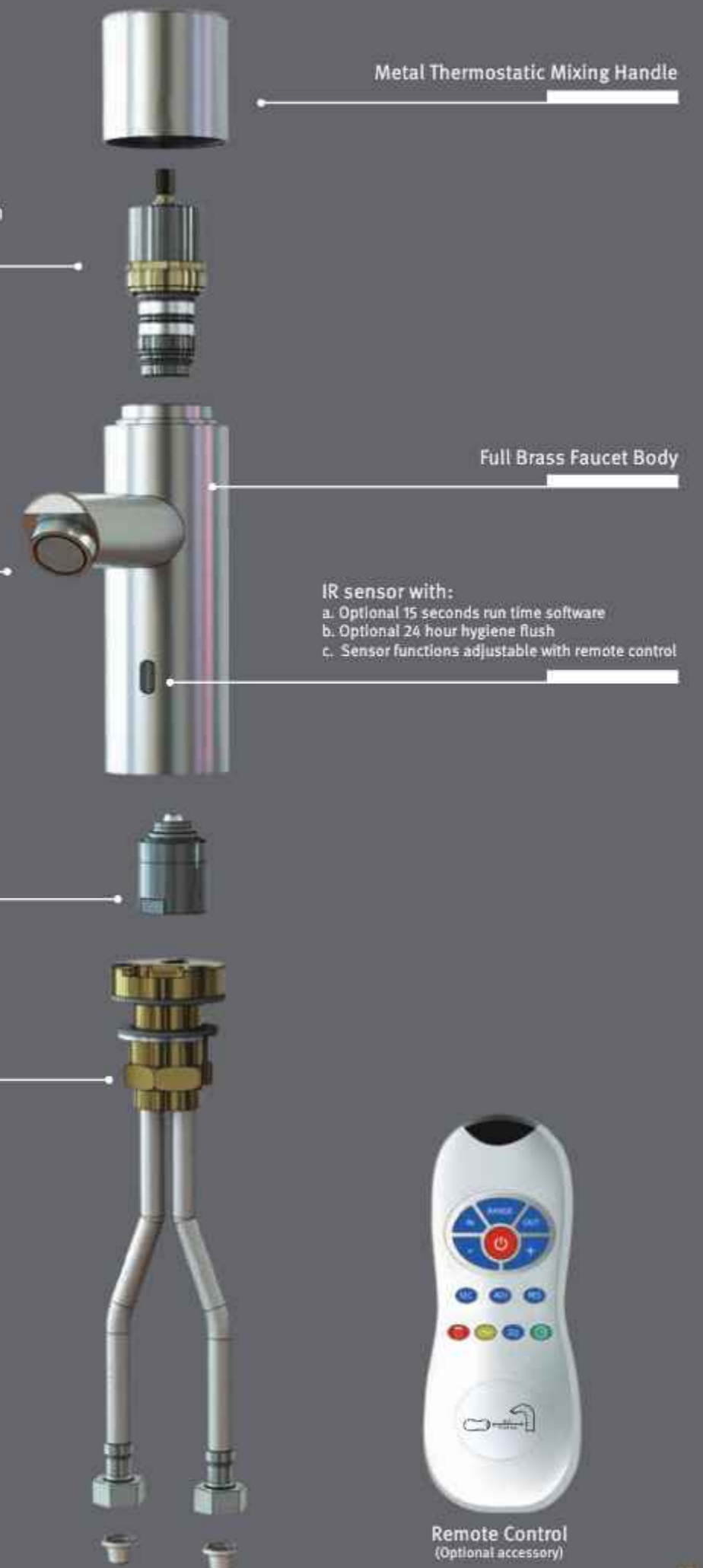

Metal Thermostatic Mixing Handle

Thermostatic Cartridge integrated with internal comfort stopper

SSR PCA Stream aerator  
A special aerator that allows you to adjust the water stream direction on site to prevent water splashing

Full Brass Faucet Body

IR sensor with:  
a. Optional 15 seconds run time software  
b. Optional 24 hour hygiene flush  
c. Sensor functions adjustable with remote control

Solenoid Valve

Faucet base & Flexible pipes

Remote Control  
(Optional accessory)

## EXTREME SERIES

### Electronic lavatory faucet operated by IR sensor

Series includes options for cold or premixed water as well as hot and cold water, long spout and tall versions for counter top sinks. Furthermore, this series includes a solenoid valve, located inside the product, which makes it more resistant to vandalism.



WATER SAVING OPTIONS		
6 LPM	1.58 GPM	SSR PCA Stream
4 LPM	1 GPM	PCA Spray
3 LPM	0.8 GPM	PCA Spray
1.69 LPM	0.5 GPM	PCA Spray
1.3 LPM	0.35 GPM	PCA Spray

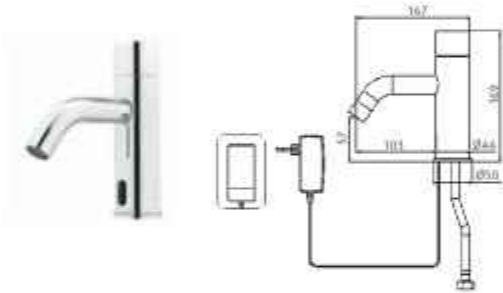

### EXTREME

- 237200 EXTREME B, 9V Battery
- 237300 EXTREME E, 9V Transformer

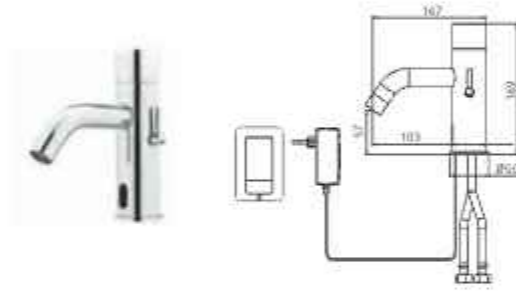

### EXTREME 1000

Mixer to adjust water temperature

- 237100 EXTREME 1000 B, 9V Battery
- 237000 EXTREME 1000 E, 9V Transformer

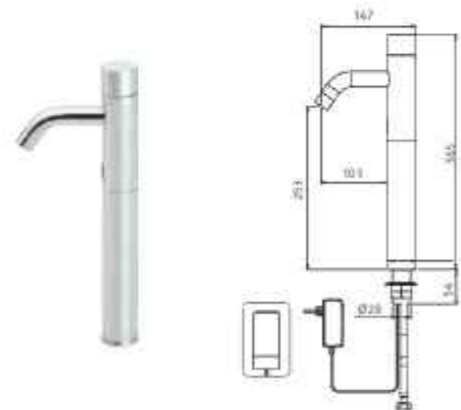

### EXTREME PLUS

Tall version for counter top wash basins

- 237250 EXTREME PLUS B, 9V Battery
- 237350 EXTREME PLUS E, 9V Transformer



### EXTREME 1000 PLUS

Tall version for counter top wash basins

Mixer to adjust water temperature

- 237150 EXTREME 1000 PLUS B, 9V Battery
- 237050 EXTREME 1000 PLUS E, 9V Transformer

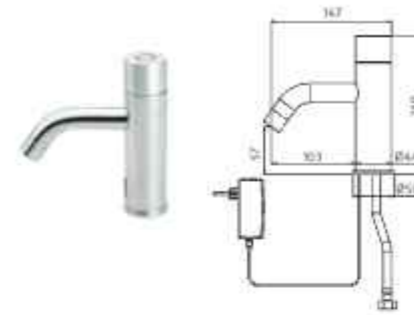

### EXTREME BRE

Permanent ring illumination. When a user places his hands within the sensor range, the ring of light blinks while water flows from the faucet.

- 237305 EXTREME BRE, 9V Transformer

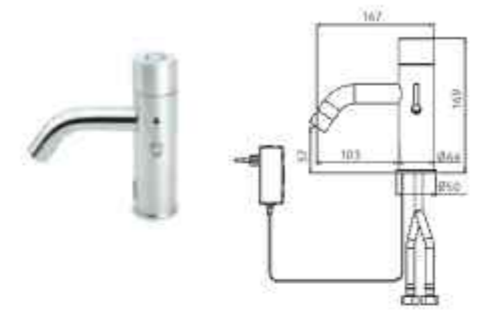

### EXTREME 1000 BRE

Mixer to adjust water temperature. Permanent ring illumination. When a user places his hands within the sensor range, the ring of light blinks while water flows from the faucet.

- 237005 EXTREME 1000 BRE, 9V Transformer



### EXTREME HL

Long spout 176mm.

Body diameter Ø38. Dual power input box. When powered by a 9V transformer features an integrated backup system to be used with a 9V Lithium Battery, which enables the product to be used normally in case of a power failure.

- 237317 EXTREME HLB, 9V Battery
- 237316 EXTREME HLE, 9V Transformer
- 237340 EXTREME HLB LF, 9V Battery, Lead Free version
- 237341 EXTREME HLE LF, 9V Transformer, Lead Free version

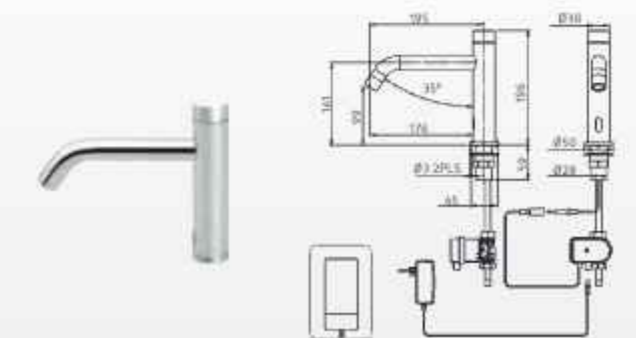

## EXTREME LF SERIES

Electronic lavatory faucet operated by IR sensor

Lead free faucet for cold or premixed water as well as hot and cold water, with a concealed sensor integrated into the spout.

WATER SAVING OPTIONS		
4 LPM	1 GPM	Honeycomb TT
1.89 LPM	0.5 GPM	PCA Spray

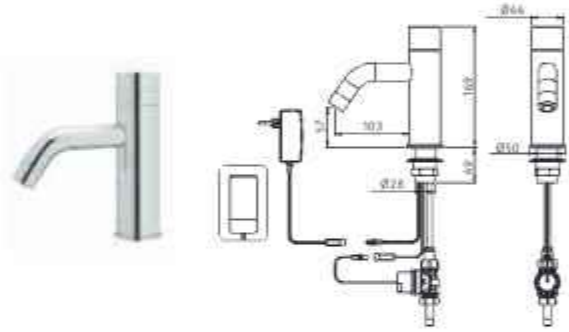

### EXTREME LF

Lead free version with concealed sensor at the spout

- 237820 EXTREME LFB, 9V Battery
- 237810 EXTREME LFE, 9V Transformer



### EXTREME 1000 LF

Mixer to adjust water temperature

- 237102 EXTREME 1000 LFB, 9V Battery
- 237003 EXTREME 1000 LFE, 9V Transformer

## QUADRAT DM SERIES

Electronic lavatory faucet operated by IR sensor

Series includes options for cold or premixed water as well as hot and cold water.

WATER SAVING OPTIONS		
6 LPM	1.58 GPM	SSR PCA Stream
4 LPM	1 GPM	PCA Spray
3 LPM	0.8 GPM	PCA Spray
1.89 LPM	0.5 GPM	PCA Spray
1.3 LPM	0.35 GPM	PCA Spray

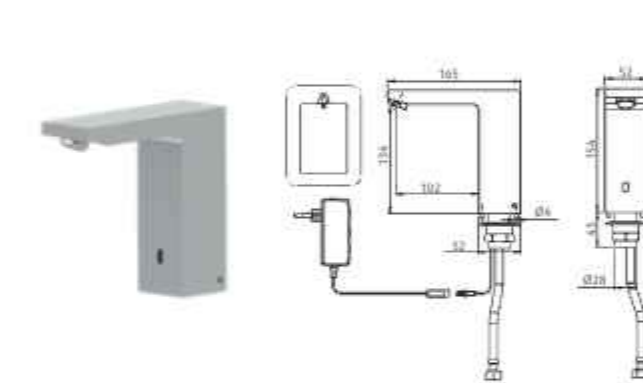

### QUADRAT DM

- 351020 QUADRAT DM B, 6 X 1.5V AA batteries
- 351010 QUADRAT DM E, 9V Transformer

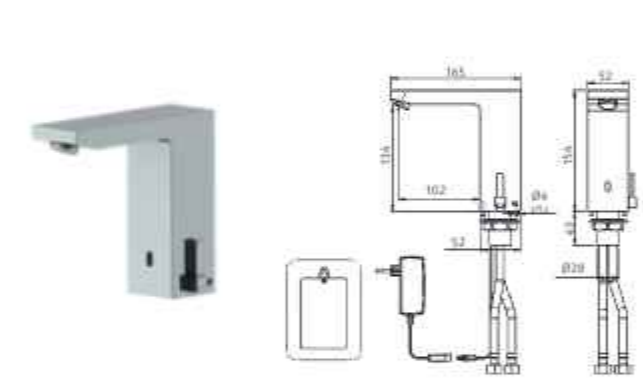

### QUADRAT 1000 DM

- 351500 QUADRAT 1000 DM B, 6 X 1.5V AA batteries
- 351510 QUADRAT 1000 DM E, 9V Transformer

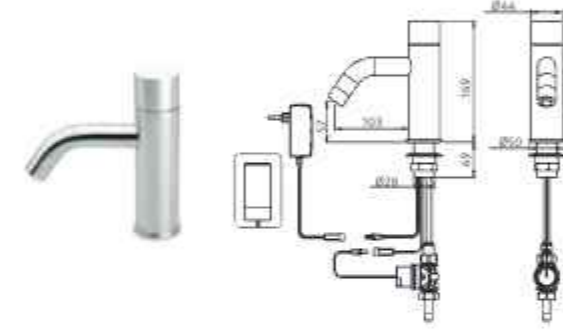

### EXTREME LF AISI316

Stainless steel AISI 316 body. Ideal for medical and coastal environments

- 237821 EXTREME LFB AISI316, 9V Battery
- 237811 EXTREME LFE AISI316, 9V Transformer



### EXTREME 1000 LF AISI316

Stainless steel AISI 316 body  
Mixer to adjust water temperature

- 237103 EXTREME 1000 LFB AISI316, 9V Battery
- 237004 EXTREME 1000 LFE AISI316, 9V Transformer



# ELITE SERIES

## Electronic lavatory faucet operated by IR sensor

Series includes options for cold or premixed water as well as hot and cold water, long spout and tall versions for counter top sinks.

Furthermore, this series includes a solenoid valve, located inside the product, which makes it more resistant to vandalism.

WATER SAVING OPTIONS		
6 LPM	1.58 GPM	SSR PCA Stream
4 LPM	1 GPM	PCA Spray
3 LPM	0.8 GPM	PCA Spray
1.89 LPM	0.5 GPM	PCA Spray
1.3 LPM	0.35 GPM	PCA Spray

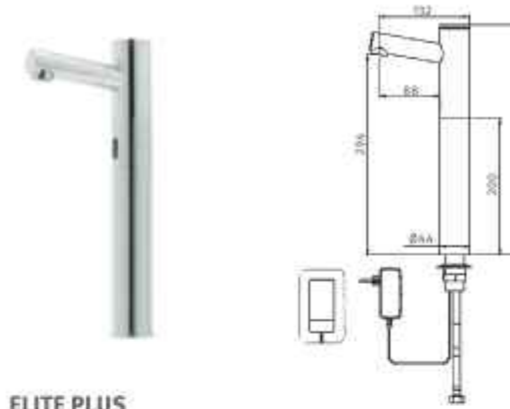

### ELITE PLUS

Tall version for counter top wash basins

- 236350 ELITE PLUS B, 9V Battery
- 236450 ELITE PLUS E, 9V Transformer

### ELITE AISI316

Stainless steel AISI 316 body

- 236453 ELITE PLUS E AISI316, 9V Transformer



### ELITE

- 236300 ELITE B, 9V Battery
- 236400 ELITE E, 9V Transformer

### ELITE AISI316

Stainless steel AISI 316 body

- 236404 ELITE E AISI316, 9V Transformer



### ELITE 1000

Mixer to adjust water temperature

- 236700 ELITE 1000 B, 9V Battery
- 236800 ELITE 1000 E, 9V Transformer

### ELITE 1000 AISI316

Stainless steel AISI 316 body.

- 236803 ELITE 1000 E AISI316, 9V Transformer

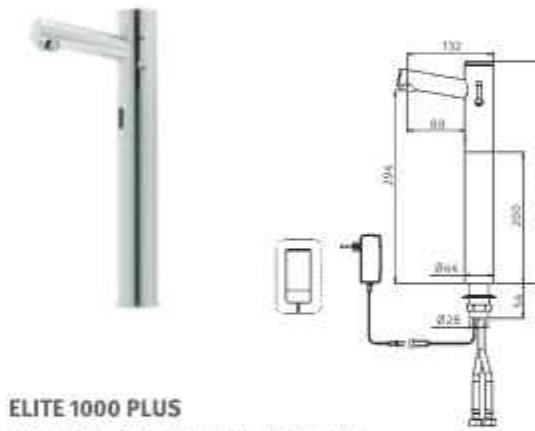

### ELITE 1000 PLUS

Tall version for counter top wash basins

Mixer to adjust water temperature

- 236750 ELITE 1000 PLUS B, 9V Battery
- 236850 ELITE 1000 PLUS E, 9V Transformer

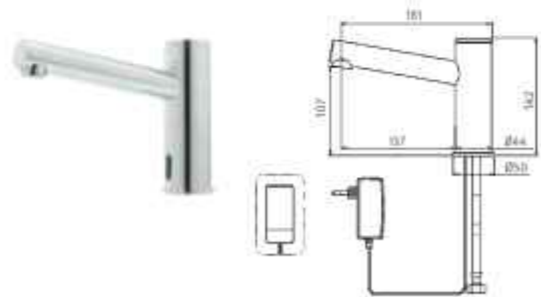

### ELITE L

Extra long spout 138mm

- 236500 ELITE LB, 9V Battery
- 236600 ELITE LE, 9V Transformer

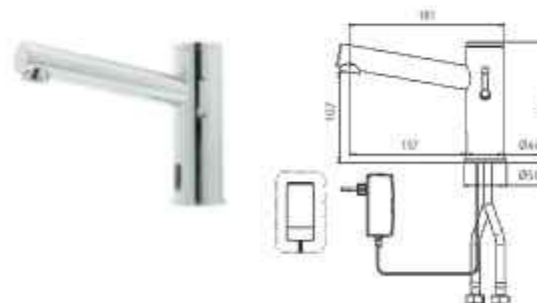

### ELITE 1000 L

Mixer to adjust water temperature

Extra long spout 138mm

- 236550 ELITE 1000 LB, 9V Battery
- 236650 ELITE 1000 LE, 9V Transformer



### ELITE 1000 with Technician's Mixer

Mixer to adjust water temperature

Option to remove the mixing handle to allow maintenance staff only, to adjust water temperature

- 236720 ELITE 1000 B with Technician's Mixer, 9V Battery
- 236805 ELITE 1000 E with Technician's Mixer, 9V Transformer



# SMART SERIES

## Electronic lavatory faucet operated by IR sensor

Series includes options for cold or premixed water as well as hot and cold water, long spout and tall versions for counter top sinks.



WATER SAVING OPTIONS		
6 LPM	1.58 GPM	SSR PCA Stream
4 LPM	1 GPM	PCA Spray
3 LPM	0.8 GPM	PCA Spray
1.89 LPM	0.5 GPM	PCA Spray
1.3 LPM	0.35 GPM	PCA Spray

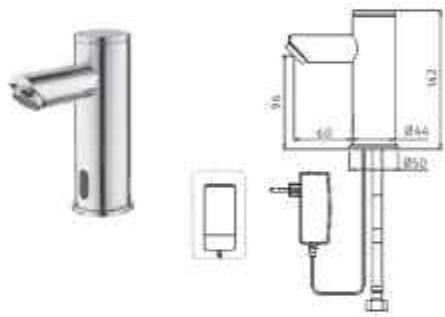

### SMART

- 235100 **SMART B**, 9V Battery
- 235200 **SMART E**, 9V Transformer

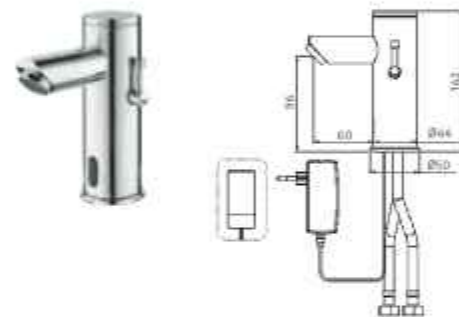

### SMART 1000

Mixer to adjust water temperature

- 235500 **SMART 1000 B**, 9V Battery
- 235600 **SMART 1000 E**, 9V Transformer

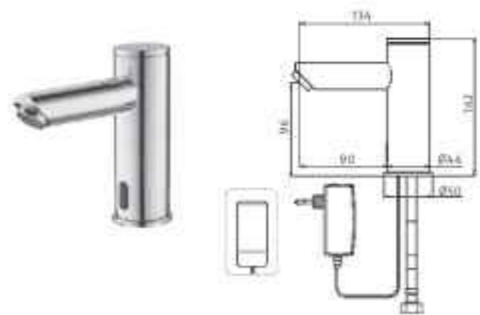

### SMART L

Extra long spout 90mm

- 235110 **SMART LB**, 9V Battery
- 235210 **SMART LE**, 9V Transformer

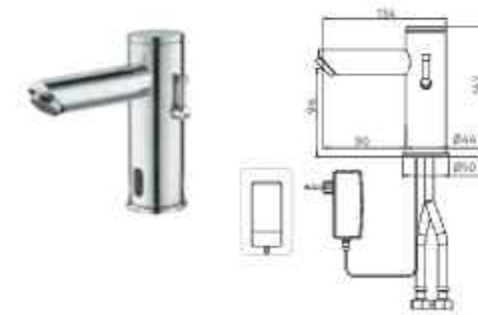

### SMART 1000 L

Extra long spout 90mm

Mixer to adjust water temperature

- 235510 **SMART 1000 LB**, 9V Battery
- 235610 **SMART 1000 LE**, 9V Transformer

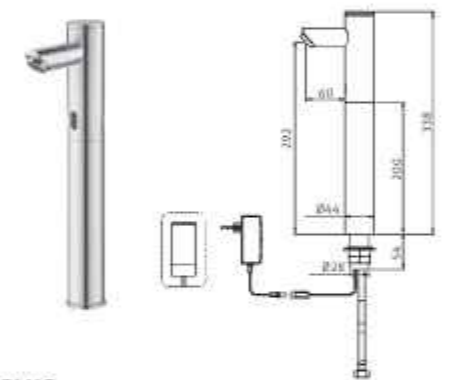

### SMART PLUS

Tall version for counter top wash basins

- 235150 **SMART PLUS B**, 9V Battery
- 235250 **SMART PLUS E**, 9V Transformer

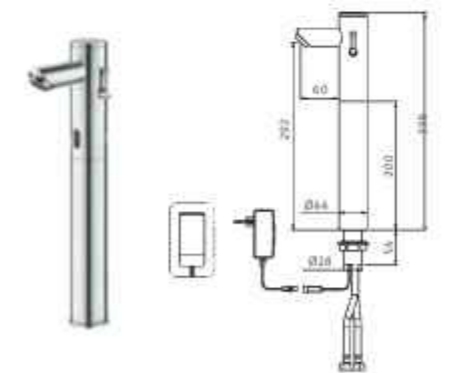

### SMART 1000 PLUS

Tall version for counter top wash basins  
Mixer to adjust water temperature

- 235550 **SMART 1000 PLUS B**, 9V Battery
- 235650 **SMART 1000 PLUS E**, 9V Transformer



## GREEN SERIES

### Electronic lavatory faucet operated by IR sensor

Series includes options for cold or premixed water as well as hot and cold water. Includes ring illuminated versions (electronically operated).



WATER SAVING OPTIONS		
6 LPM	1.58 GPM	SSR PCA Stream
4 LPM	1 GPM	PCA Spray
3 LPM	0.8 GPM	PCA Spray
1.89 LPM	0.5 GPM	PCA Spray
1.3 LPM	0.35 GPM	PCA Spray



#### GREEN AB1953

- 225901 GREEN AB1953, Internal 9V Battery

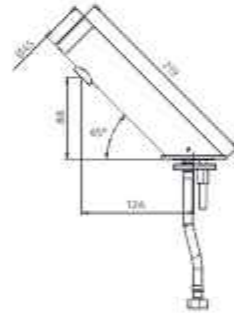

#### GREEN B/E AB1953

- 225951 GREEN B AB1953, 9V Battery
- 225941 GREEN E AB1953, 9V Transformer

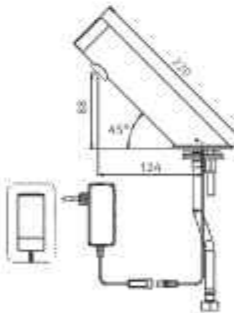

#### GREEN BRE AB1953

Features a permanent ring illumination. When a user places his hands within the sensor range, the ring of light blinks while water flows from the faucet.

- 225921 GREEN BRE AB1953, 9V Transformer



#### GREEN 1000 AB1953

Mixer to adjust water temperature

- 225801 GREEN 1000 AB1953, Internal 9V Battery

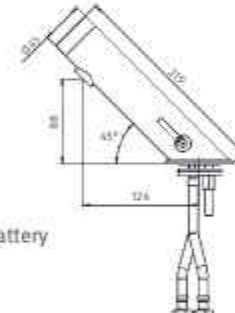

#### GREEN 1000 B/E AB1953

Mixer to adjust water temperature

- 225871 GREEN 1000 B AB1953, 9V Battery
- 225821 GREEN 1000 E AB1953, 9V Transformer

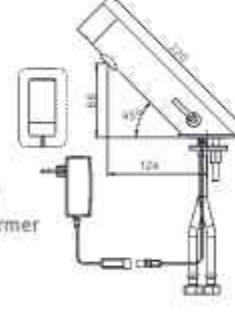

#### GREEN 1000 BRE AB1953

Mixer to adjust water temperature

Features a permanent ring illumination. When a user places his hands within the sensor range, the ring of light blinks while water flows from the faucet.

- 225891 GREEN 1000 BRE AB1953, 9V Transformer

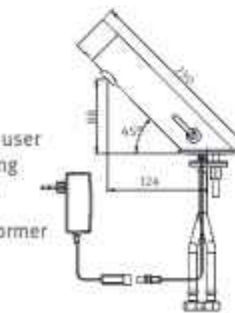

## TOUCH FREE SERIES

### Electronic lavatory faucet operated by IR sensor

For cold or premixed water.

WATER SAVING OPTIONS		
5 LPM	1.32 GPM	Cache
1.89 LPM	0.5 GPM	PCA Spray

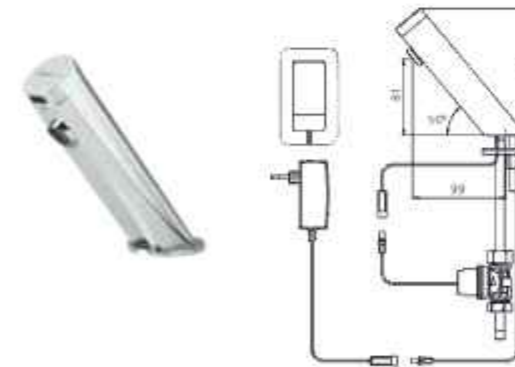

#### TOUCH FREE AB1953

- 225610 TOUCH FREE B AB1953, 9V Battery
- 225710 TOUCH FREE E AB1953, 9V Transformer



## TUBULAR DM SERIES

### Electronic lavatory faucet operated by IR sensor

For cold or premixed water.

WATER SAVING OPTIONS		
6 LPM	1.58 GPM	SSR PCA STREAM
4 LPM	1 GPM	PCA Spray
3 LPM	0.8 GPM	PCA SPRAY
1.89 LPM	0.5 GPM	PCA Spray
1.3 LPM	0.35 GPM	PCA SPRAY

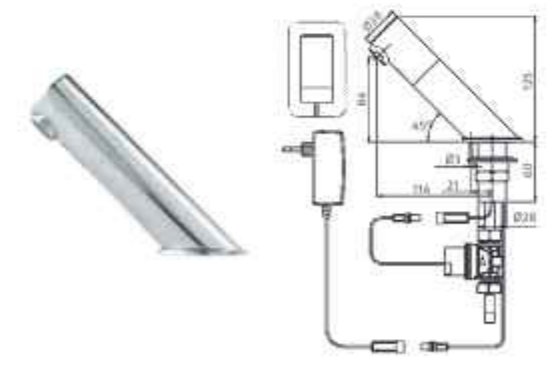

#### TUBULAR DM

- 350700 TUBULAR DMB, 9V Battery
- 350750 TUBULAR DME, 9V Transformer

## CLASSIC SERIES

### Electronic lavatory faucet operated by IR sensor

Series includes options for cold or premixed water as well as hot and cold water.



WATER SAVING OPTIONS		
6 LPM	1.58 GPM	SSR PCA STREAM
4 LPM	1 GPM	PCA Spray
3 LPM	0.8 GPM	PCA SPRAY
1.89 LPM	0.5 GPM	PCA Spray
1.3 LPM	0.35 GPM	PCA SPRAY



#### CLASSIC AB1953

- 291010 CLASSIC AB1953, Internal 9V Battery

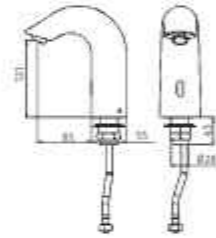

#### CLASSIC B/E AB1953

- 291110 CLASSIC B AB1953, 9V Battery
- 291210 CLASSIC E AB1953, 9V Transformer

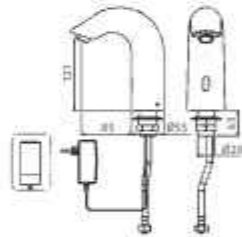

#### CLASSIC 1000 AB1953

- Mixer to adjust water temperature
- 292020 CLASSIC 1000 B AB1953, Internal 9V Battery

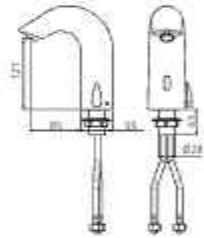

#### CLASSIC 1000 B/E AB1953

- Mixer to adjust water temperature
- 292120 CLASSIC 1000 B AB1953, 9V Battery
  - 292230 CLASSIC 1000 E AB1953, 9V Transformer

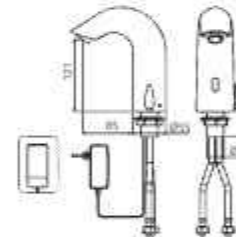

#### CLASSIC CS

- Concealed sensor
- 293100 CLASSIC CS B, 9V Battery
  - 293200 CLASSIC CS E, 9V Transformer

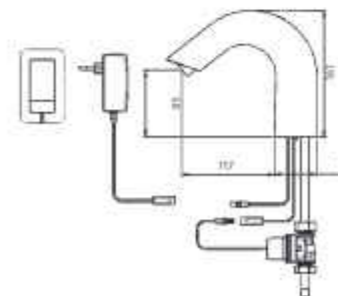

## EASY SERIES

### Electronic lavatory faucet operated by IR sensor

This structure is a one piece solid brass for added vandal resistance.



WATER SAVING OPTIONS		
6 LPM	1.58 GPM	SSR PCA STREAM
4 LPM	1 GPM	PCA Spray
3 LPM	0.8 GPM	PCA SPRAY
1.89 LPM	0.5 GPM	PCA Spray
1.3 LPM	0.35 GPM	PCA SPRAY



#### EASY

- Cold or premixed water
- 246010 EASY B, 9V Battery
  - 246020 EASY E, 9V Transformer

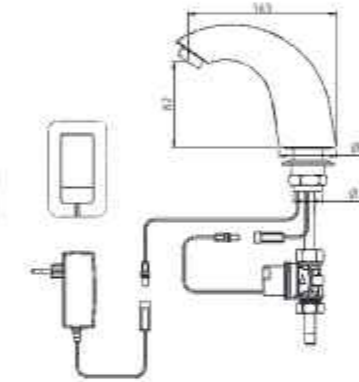

#### EASY 1000

- Option to remove the mixing handle to allow maintenance staff only, to adjust water temperature
- 246050 EASY 1000 B, 9V Battery
  - 246060 EASY 1000 E, 9V Transformer

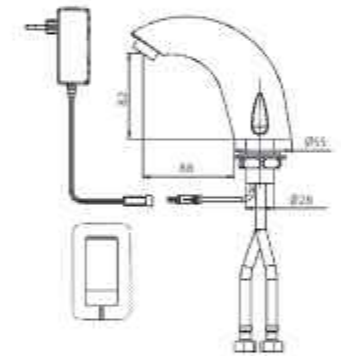

EASY WITH COVERPLATE  
see page 145

## SWAN SERIES

### Electronic lavatory faucet operated by IR sensor

Series includes options for cold or premixed water as well as hot and cold water.

Furthermore, this series includes a solenoid valve, located inside the product, which makes it more resistant to vandalism.



WATER SAVING OPTIONS		
6 LPM	1.58 GPM	SSR PCA STREAM
4 LPM	1 GPM	PCA Spray
3 LPM	0.8 GPM	PCA SPRAY
1.89 LPM	0.5 GPM	PCA Spray
1.3 LPM	0.35 GPM	PCA SPRAY



#### SWAN 1010 AB1953

- 250220 SWAN 1010 AB1953, Internal 9V Battery

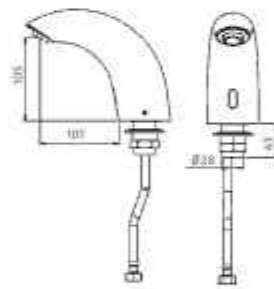

#### SWAN 1010 B/E AB1953

- 250310 SWAN 1010 B AB1953, 9V Battery
- 250420 SWAN 1010 E AB1953, 9V Transformer

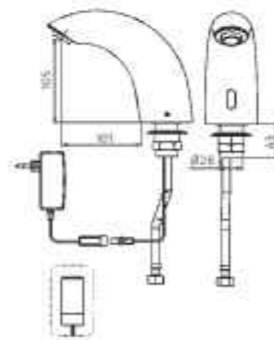

#### SWAN 1000 AB1953

Mixer to adjust water temperature

- 252210 SWAN 1000 AB1953, Internal 9V Battery

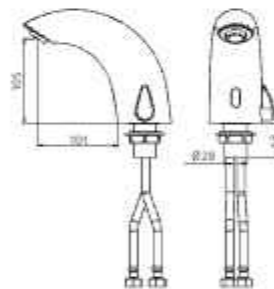

#### SWAN 1000 B/E AB1953

Mixer to adjust water temperature

- 252310 SWAN 1000 B AB1953, 9V Battery
- 252420 SWAN 1000 E AB1953, 9V Transformer

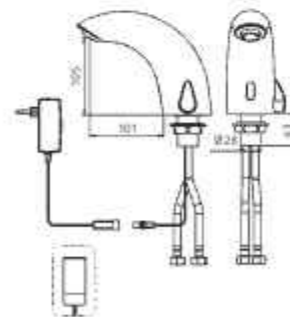

## CONDOR SERIES

### Electronic lavatory faucet operated by IR sensor

For cold or premixed water.

IP67 Dual power input box that allows the faucet to be used with a 9V battery. Can be also be powered by a 9V transformer which includes an integrated backup system to be used with a 9V Lithium battery. This enables the product to be used normally in case of a power failure.



WATER SAVING OPTIONS		
6 LPM	1.58 GPM	SSR PCA STREAM
4 LPM	1 GPM	PCA Spray
3 LPM	0.8 GPM	PCA SPRAY
1.89 LPM	0.5 GPM	PCA Spray
1.3 LPM	0.35 GPM	PCA SPRAY



#### CONDOR 1010

- 210100 CONDOR 1010, 9V Battery
- 210300 CONDOR 1010 E, 9V Transformer

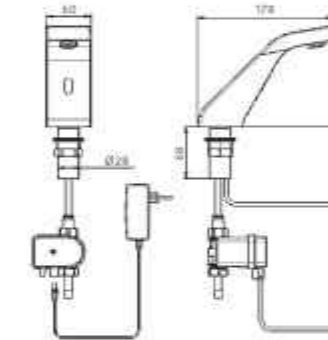

#### CONDOR

Integrated panel versions

- 210000 CONDOR, 9V Battery
- 210200 CONDOR E, 9V Transformer

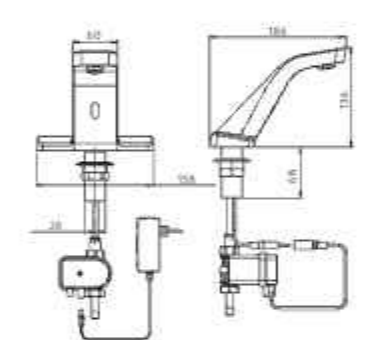

## DOLPHIN SERIES

Electronic lavatory faucet operated by IR sensor

Series includes options for cold or premixed water as well as hot and cold water.

WATER SAVING OPTIONS		
6 LPM	1.58 GPM	SSR PCA STREAM
4 LPM	1 GPM	PCA Spray
3 LPM	0.8 GPM	PCA SPRAY
1.89 LPM	0.5 GPM	PCA Spray
1.3 LPM	0.35 GPM	PCA SPRAY



### DOLPHIN FB

- 270170 DOLPHIN FB, 9V Battery
- 270180 DOLPHIN FE, 9V Transformer



### DOLPHIN 1000 FB

Mixer to adjust water temperature  
Internal solenoid

- 270320 DOLPHIN 1000 FB, 9V Battery
- 270330 CDOLPHIN 1000 FE, 9V Transformer



### DOLPHIN GB

Gooseneck tall spout

- 270120 DOLPHIN GB, 9V Battery
- 270220 DOLPHIN GE, 9V Transformer



**NEW!**

## COOL TF SERIES

Touch-free electronic glass or bottle filler faucet activated by IR sensor



### COOL TF

Long reach spout

- 280150 COOL TFB, 9V Battery
- 280140 COOL TFE, 9V Transformer

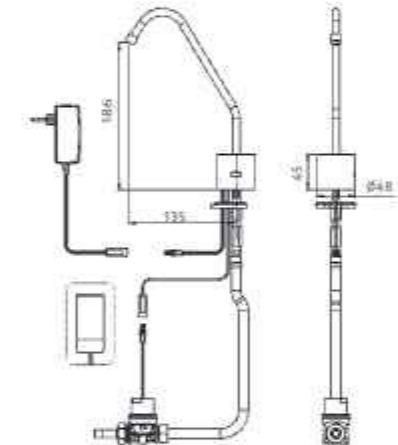

### COOL TF G

- 280160 COOL TF GB, 9V Battery
- 280170 COOL TF GE, 9V Transformer

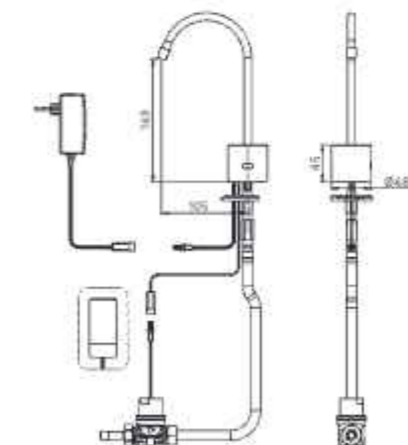



# WALL MOUNTED FAUCETS

	EXTREME CS	31		APOLLO AL	40
	MALMO	32		MEDICAL	41 - 42
	D28	33 - 34		APOLLO FREE	43
	TUBULAR	35 - 37		WASHFREE 1000	43
	QUADRAT	38		PROX, WAVE & TOUCH SOLUTIONS	44
	NARA Q	39			

## EXTREME CS SERIES

Electronic wall mounted faucet operated by a concealed IR sensor integrated into the spout

For cold or premixed water.

IP67 Dual power input box that allows the faucet to be used with a 9V battery or a 9V transformer. Dual power input box used as an integrated backup system with a 9V Lithium battery, for continued use in case of power failure.



WATER SAVING OPTIONS		
4 LPM	1 GPM	Honeycomb TT
1.39 LPM	0.5 GPM	PCA Spray

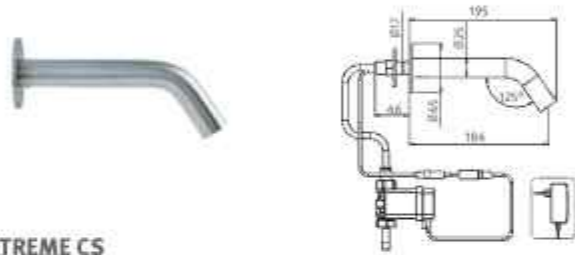

### EXTREME CS

Concealed installation in dry walls

- 237801 EXTREME CS B, 9V Battery
- 237800 EXTREME CS E, 9V Transformer

### EXTREME CS AISI316

Stainless steel 316 body

Concealed installation in dry walls

- 237801-316 EXTREME CS B AISI316, 9V Battery
- 237800-316 EXTREME CS E AISI316, 9V Transformer



## MALMO SERIES

Electronic wall mounted faucet operated by IR sensor

Solenoid valve, sensor and battery are integrated in the spout.

Series includes options for cold or premixed water as well as hot and cold water.



WATER SAVING OPTIONS		
6 LPM	1.58 GPM	SSR PCA Stream
4 LPM	1 GPM	PCA Spray
3 LPM	0.8 GPM	PCA Spray
1.89 LPM	0.5 GPM	PCA Spray
1.3 LPM	0.35 GPM	PCA Spray

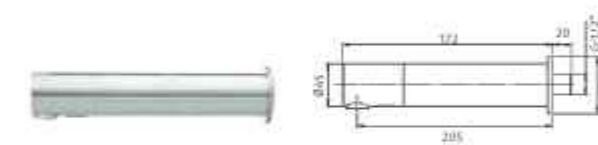

### MALMO

Concealed installation in concrete or brick walls

- 225865 MALMO, 9V Battery

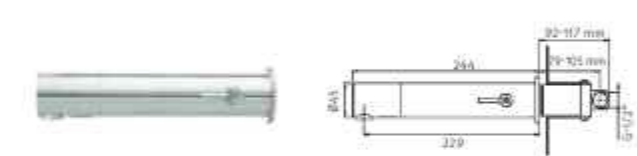

### MALMO 1000

Concealed installation in concrete or brick walls

Mixer to adjust water temperature

- 225860 MALMO 1000, 9V Battery
- 225861 MALMO 1000 E, 9V Transformer

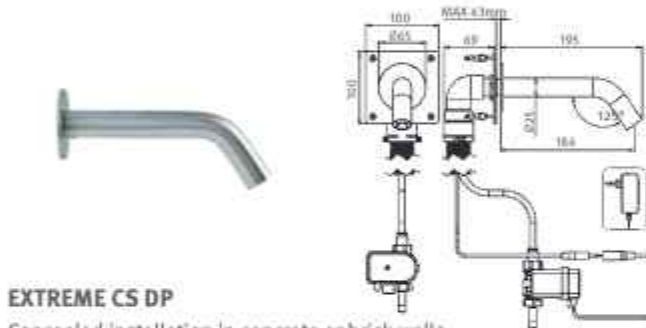

### EXTREME CS DP

Concealed installation in concrete or brick walls

- 237802 EXTREME CS DPB, 9V Battery
- 237803 EXTREME CS DPE, 9V Transformer

### EXTREME CS DP AISI316

Stainless steel 316 body

Concealed installation in concrete or brick walls

- 237802-316 EXTREME CS DPB AISI316, 9V Battery
- 237803-316 EXTREME CS DPE AISI316, 9V Transformer

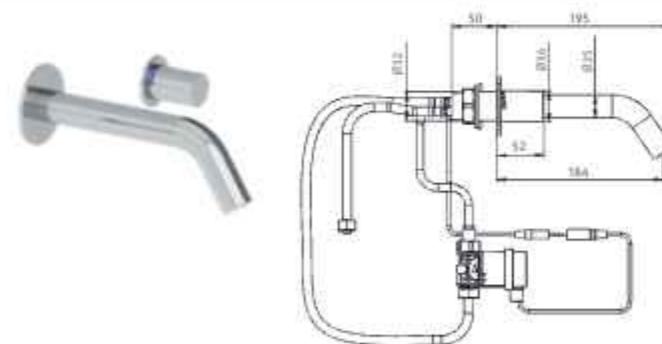

### EXTREME CS 1000

Touch-free wall-mounted electronic faucet. With thermostatic mixer for water temperature adjustment for hot and cold water.

- 237720 EXTREME CS 1000B, 9V Battery
- 237710 EXTREME CS 1000E, 9V Transformer

### EXTREME CS 1000 AISI316

Stainless steel 316 body

- 237715 EXTREME CS 1000B AISI316, 9V Battery
- 237725 EXTREME CS 1000E AISI316, 9V Transformer



## D28 SERIES

Electronic wall mounted faucet operated by IR sensor  
For cold or premixed water.



WATER SAVING OPTIONS		
5 LPM	1.32 GPM	HONEYCOMB TT
1.89 LPM	0.5 GPM	PCA SPRAY

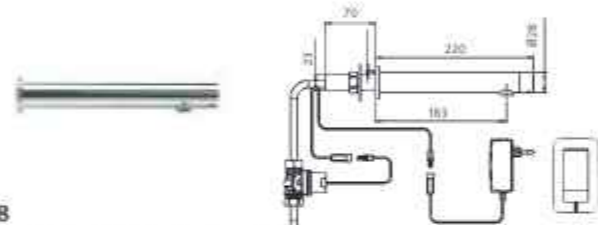

### D28

Concealed installation in dry walls  
Iron frame available (see page 136).

- 352000 D28, 9V Battery
- 352100 D28 E, 9V Transformer

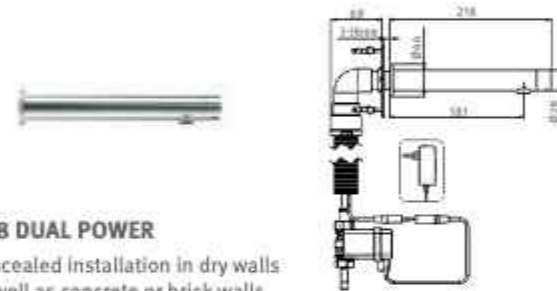

### D28 DUAL POWER

Concealed installation in dry walls  
as well as concrete or brick walls.

Dual power input box

- 352300 D28 DUAL POWER B, 9V Battery
- 352400 D28 DUAL POWER E, 9V Transformer

When powered by a 9V transformer features an integrated backup system  
to be used with a 9V Lithium Battery, which enables the product to be used  
normally in case of a power failure. Iron Frame available (see page 136)

LONG SPOUT

### D28 L

Long spout 275 mm

- 352010 D28 LB, 6 x 1.5 AA Batteries
- 352110 D28 LE, 9V Transformer



### D28 DUAL POWER L

Long spout 275 mm

- 352303 D28 DUAL POWER LB, 9V Battery
- 352410 D28 DUAL POWER LE, 9V Transformer

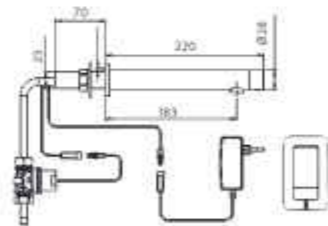

### D28 AISI316

Concealed installation in dry walls  
Stainless steel 316 body

- 352130 D28 AISI316, 9V Battery
- 352120 D28 E AISI316, 9V Transformer

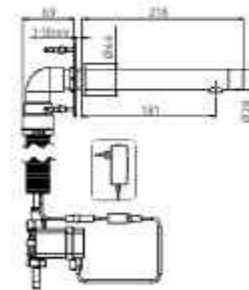

### D28 DUAL POWER AISI316

Concealed installation in dry walls  
as well as concrete or brick walls

Stainless steel 316 body

- 352301 D28 DPB AISI316, 9V Battery
- 352401 D28 DPE AISI316, 9V Transformer

LONG SPOUT

### D28 L AISI316

Long spout 275 mm

- 352015 D28 LB AISI316, 9V Battery
- 352125 D28 LE AISI316, 9V Transformer



### D28 DP L AISI316

Long spout 275 mm

- 352304 D28 DP LB AISI316, 9V Battery
- 352403 D28 DP LE AISI316, 9V Transformer



# TUBULAR SERIES

## Electronic wall mounted faucet operated by IR sensor

Series includes options for cold or premixed water as well as hot and cold water, long spout and various installation options.



WATER SAVING OPTIONS		
6 LPM	1.58 GPM	SSR PCA Stream
4 LPM	1 GPM	PCA Spray
3 LPM	0.8 GPM	PCA Spray
1.89 LPM	0.5 GPM	PCA Spray
1.3 LPM	0.35 GPM	PCA Spray

**TUBULAR**  
Concealed installation in dry walls

- 350200 TUBULAR B, 6 x 1.5 AA Batteries
- 350100 TUBULAR E, 9V Transformer

**LONG SPOUT**

**TUBULAR L**  
Long spout 220 mm

- 350210 TUBULAR LB, 6 x 1.5 AA Batteries
- 350120 TUBULAR LE, 9V Transformer

**TUBULAR AISI316**  
Stainless steel 316 body  
Concealed installation in dry walls  
Iron frame available (see page 136)

- 350208 TUBULAR B AISI316, 6 x 1.5 AA Batteries
- 350109 TRENDY E AISI316, 9V Transformer

**LONG SPOUT**

**TUBULAR L AISI316**  
Long spout 220 mm

- 350213 TUBULAR LB AISI316, 6 x 1.5 AA Batteries
- 350124 TRENDY LE AISI316, 9V Transformer

**TUBULAR 2030**  
Concealed installation in concrete or brick walls

- 350300 TUBULAR 2030 B, 9V Battery
- 350400 TUBULAR 2030 E, 9V Transformer

**TUBULAR 2030 L**  
Long spout 220 mm

- 350310 TUBULAR 2030 LB, 9V Battery
- 350410 TUBULAR 2030 LE, 9V Transformer

**TUBULAR 2030 AISI316**  
Stainless steel 316 body  
Concealed installation in concrete or brick walls  
Iron frame available (see page 136)

- 350402 TRENDY 2030E AISI316, 9V Transformer

**TUBULAR 2030 L AISI316**  
Long spout 220 mm

- 350412 TRENDY 2030LE AISI316, 9V Transformer

**TUBULAR XL**  
Concealed installation in dry walls  
Extra long spout 295 mm

- 350215 TUBULAR XLB, 6 x 1.5 AA Batteries
- 350415 TUBULAR XLE, 9V Transformer

**TUBULAR XL DP**  
Concealed installation in dry walls as well as concrete or brick walls  
Dual power input box

- 350224 TUBULAR XL DPB, 9V Battery
- 350223 TUBULAR XL DPE, 9V Transformer

**TUBULAR PERTH**  
Concealed installation in dry walls

- 350207 TUBULAR PERTH B, 6 x 1.5 AA Batteries
- 350107 TUBULAR PERTH E, 9V Transformer

**TUBULAR C**  
Installation from ceiling

- 350300 TUBULAR CB, 6 x 1.5 AA Batteries
- 350400 TUBULAR CE, 9V Transformer

**TUBULAR 1000 AB1953**  
Concealed installation in dry walls  
Mixer to adjust water temperature

- 350805 TUBULAR 1000 B AB1953, 6 x 1.5 AA Batteries
- 350855 TUBULAR 1000 E AB1953, 9V Transformer

**TUBULAR 1000 BOX**  
Installation in concrete or brick walls  
Mixer to adjust water temperature

- 350800 TUBULAR 1000 B BOX, 6 x 1.5 AA Batteries
- 350950 TUBULAR 1000 E BOX, 9V Transformer

**LONG SPOUT**

**TUBULAR 1000 L BOX**  
Long spout 220 mm

- 350910 TUBULAR 1000 LB BOX, 6 x 1.5 AA Batteries
- 350960 TUBULAR 1000 LE BOX, 9V Transformer





## TUBULAR WAVE DP LE

### Electronic wall mounted faucet operated by wave on-off IR sensor

For cold or premixed water. Options for installation with iron frame. When powered by a 9V transformer features an integrated backup system to be used with a 9V Lithium battery, which enables the product to be used normally in case of a power failure. Allows activation of the faucet once the users place their hands at a close proximity to the sensor. Water will shut off if the users place their hands at a close proximity to the sensor again or once a factory set flow time of 8 seconds will pass. The flow time is adjustable on site by remote control.



WATER SAVING OPTIONS		
6 LPM	1.58 GPM	SSR PCA Stream
4 LPM	1 GPM	PCA Spray
3 LPM	0.8 GPM	PCA Spray
1.89 LPM	0.5 GPM	PCA Spray
1.3 LPM	0.35 GPM	PCA Spray

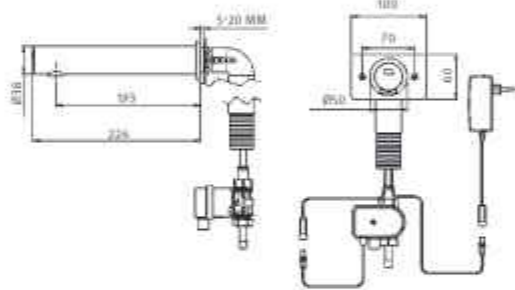

### TUBULAR WAVE DP LE

Dual power input box  
Concealed installation in dry walls as well as concrete or brick walls  
Iron frame available (see page 136)

- 350190 TUBULAR WAVE DP LE, 9V Transformer



## QUADRAT SERIES

### Electronic wall mounted faucet operated by IR sensor

Series includes options for cold or premixed water, long spout models and various installation options.



WATER SAVING OPTIONS		
6 LPM	1.58 GPM	SSR PCA Stream
4 LPM	1 GPM	PCA Spray
3 LPM	0.8 GPM	PCA Spray
1.89 LPM	0.5 GPM	PCA Spray
1.3 LPM	0.35 GPM	PCA Spray



### QUADRAT

Concealed installation in dry walls

- 351100 QUADRAT B, 6 x 1.5 AA Batteries
- 351200 QUADRAT E, 9V Transformer



### QUADRAT 2030

Concealed installation in concrete or brick walls

- 351300 QUADRAT 2030 B, 9V Battery
- 351400 QUADRAT 2030 E, 9V Transformer

LONG SPOUT

### QUADRAT L

Long spout 220 mm

- 351105 QUADRAT LB, 6 x 1.5 AA Batteries
- 351205 QUADRAT LE, 9V Transformer



### QUADRAT 2030 L

Long spout 220 mm

- 351105 QUADRAT 2030 LB, 9V Battery
- 351205 QUADRAT 2030 LE, 9V Transformer



## NARA Q SERIES

### Electronic wall mounted faucet operated by IR sensor

For cold or premixed water.

Furthermore, this series includes a solenoid valve, located inside the product, which makes it more resistant to vandalism.



WATER SAVING OPTIONS		
6 LPM	1.58 GPM	SSR PCA Stream
4 LPM	1 GPM	PCA Spray
3 LPM	0.8 GPM	PCA Spray
1.89 LPM	0.5 GPM	PCA Spray
1.3 LPM	0.35 GPM	PCA Spray

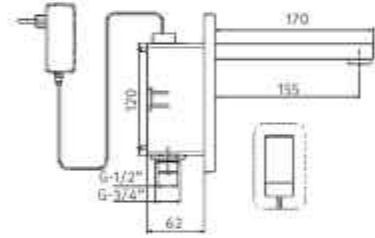

### NARA Q

Concealed installation in concrete or brick walls.

- 360510 NARA Q, 9V Battery
- 360500 NARA QE, 9V Transformer

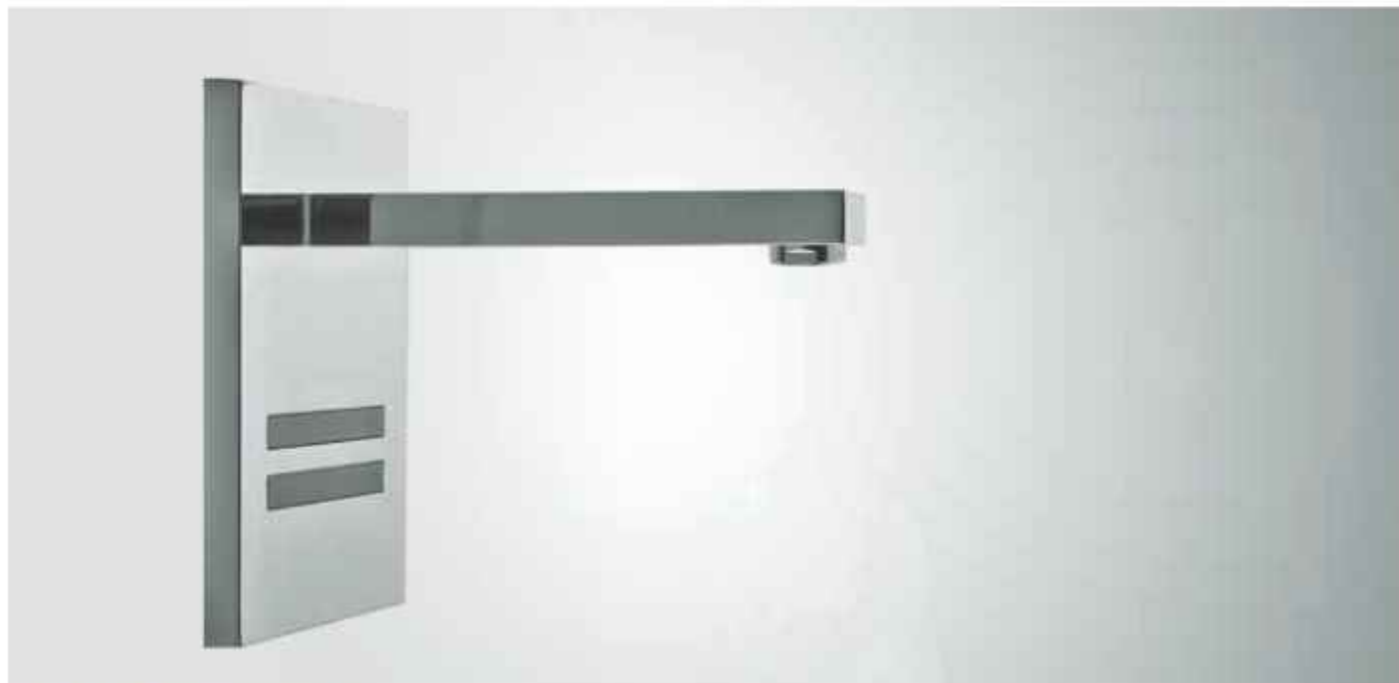

## APOLLO AL SERIES

### Electronic wall mounted faucet operated by IR sensor

For cold or premixed water.

Includes options for wave or prox operation, and accessories for brick wall installation.



WATER SAVING OPTIONS		
6 LPM	1.58 GPM	SSR PCA Stream
4 LPM	1 GPM	PCA Spray
3 LPM	0.8 GPM	PCA Spray
1.89 LPM	0.5 GPM	PCA Spray
1.3 LPM	0.35 GPM	PCA Spray

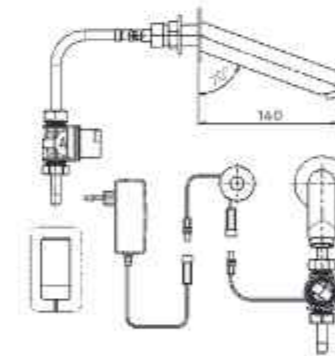

### APOLLO AL

Concealed installation in dry walls.

Default Wave activation: Once the users place their hands at a close proximity to the sensor. Water will continue to flow unless the user places their hands again, at a close proximity to the sensor again or once a factory set flow time of 8 seconds will pass. The flow time is adjustable on site by remote control.

Optional Prox activation:

Automatic activation when the users bring their hands within the sensor range, and stops when the users remove their hands.

- 340600 APOLLO ALB, 9V Battery
- 340700 APOLLO ALE, 9V Transformer

### APOLLO AL EXTENSIONS

For brick wall installations.

- 07240060 EXTENSION KIT APOLLO AL



- 07240061 EXTENSION KIT FOR WAVE / PROX SENSOR (REQUIRES A SPECIAL MATCHING SENSOR)



# MEDICAL SERIES

## Electronic wall mounted faucet operated by IR sensor

Features an integrated thermostatic mixer to prevent scalding operation and temperature control.

Furthermore, this series includes a solenoid valve, located inside the product, which makes it more resistant to vandalism.



WATER SAVING OPTIONS		
6 LPM	1.58 GPM	SSR PCA Stream
4 LPM	1 GPM	PCA Spray
3 LPM	0.8 GPM	PCA Spray
1.89 LPM	0.5 GPM	PCA Spray
1.3 LPM	0.35 GPM	PCA Spray



### APOLLO MEDICAL F

Exposed installation  
Gooseneck spout

- 314530 APOLLO MEDICAL FB, Internal 9V Battery
- 314540 APOLLO MEDICAL FE, 9V Transformer

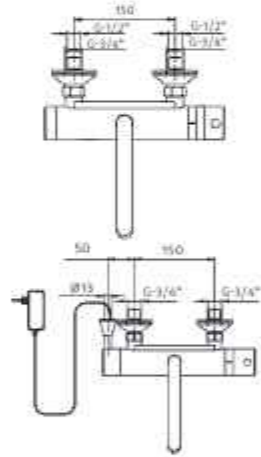

### APOLLO MEDICAL B

Exposed installation  
Swivel spout

- 314500 APOLLO MEDICAL B, Internal 9V Battery
- 314510 APOLLO MEDICAL E, 9V Transformer

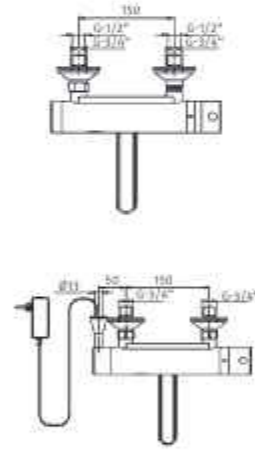

### MEDICAL 1000 T

Exposed installation  
Body integrated spout

- 314600 MEDICAL 1000 TE, 9V Transformer

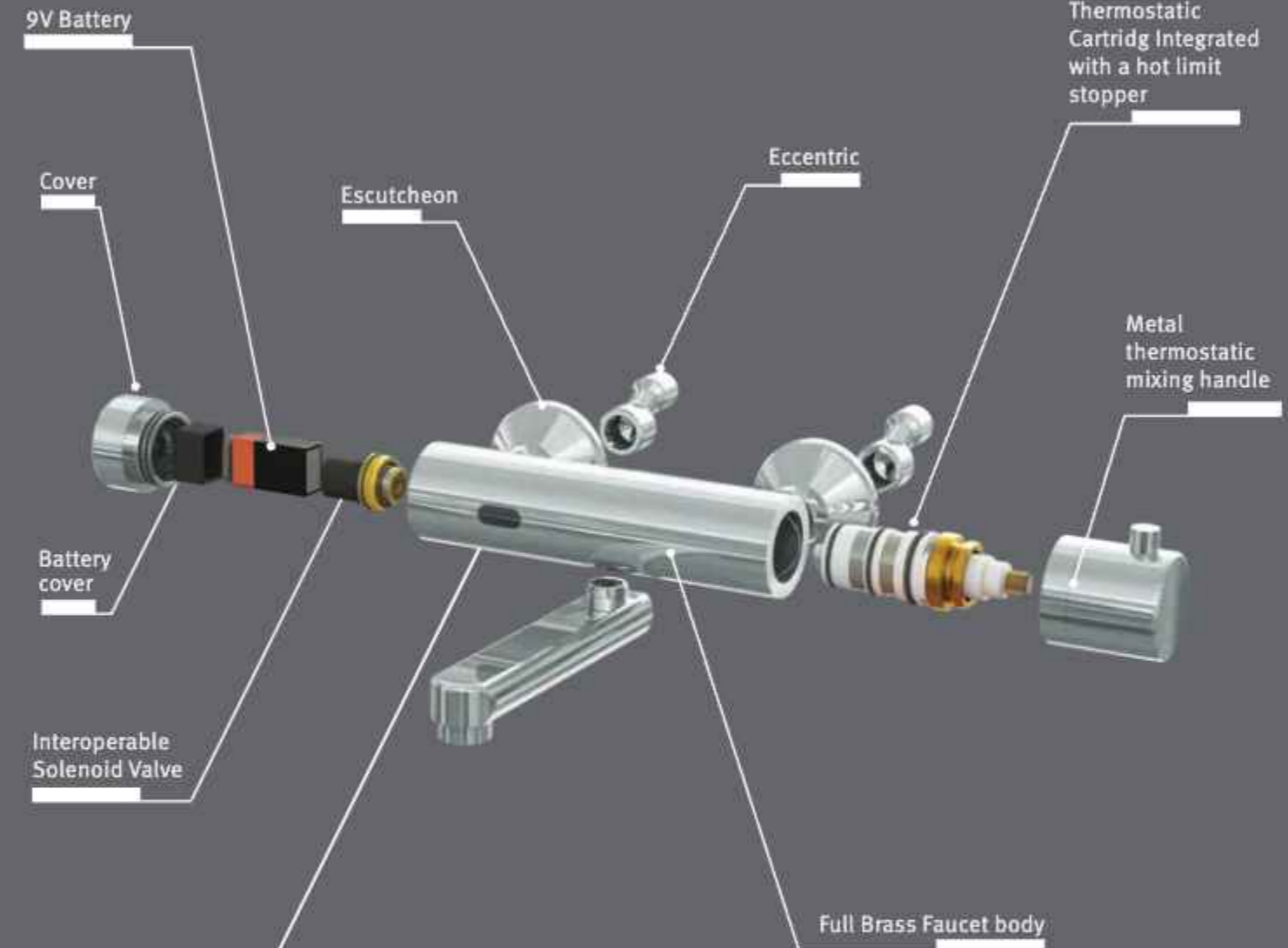
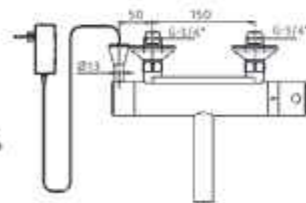

### IR SENSOR:

- Body recognition program
- Sensor functions adjustable by remote control
- Various hygiene flush options available



Remote Control  
(Optional accessory)

## APOLLO FREE SERIES

Electronic wall mounted faucet operated by IR sensor  
Powered by an internal 9V battery.  
For cold or premixed water.

WATER SAVING OPTIONS		
6 LPM	1.58 GPM	SSR PCA Stream
4 LPM	1 GPM	PCA Spray
3 LPM	0.8 GPM	PCA Spray
1.89 LPM	0.5 GPM	PCA Spray
1.3 LPM	0.35 GPM	PCA Spray

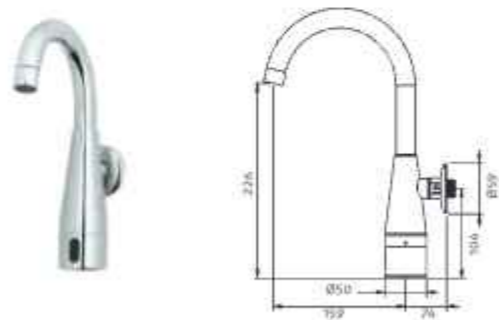

**APOLLO FREE**  
Exposed installation  
• 340100 APOLLO FREE, Internal 9V Battery

## WASHFREE 1000

Electronic wall mounted faucet operated by wave IR sensor  
For cold or premixed water. Includes option for a longer bracket.

WATER SAVING OPTIONS		
6 LPM	1.58 GPM	SSR PCA Stream
4 LPM	1 GPM	PCA Spray
3 LPM	0.8 GPM	PCA Spray
1.89 LPM	0.5 GPM	PCA Spray
1.3 LPM	0.35 GPM	PCA Spray

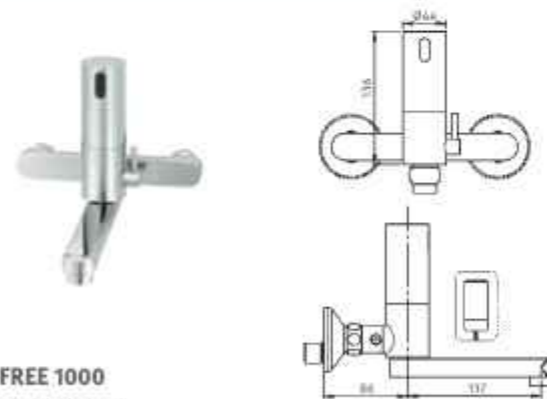

**WASHFREE 1000**  
Exposed installation  
Allows activation of the faucet once the users place their hands at a close proximity to the sensor. Water will shut off if the users place their hands at a close proximity to the sensor - again or once a factory set flow time of 8 seconds will pass. The flow time is adjustable on site by remote control. With a mixer for water temperature adjustment for hot and cold water.  
• 316010 WASHFREE 1000, 9V Battery  
• Long bracket 200 mm available upon request

## PROX, WAVE & TOUCH SOLUTIONS

Touch-free & Touch operated faucet kits operated by an IR sensor or a Piezo button

To be integrated in a faucet application to deliver water with or without touch.

For cold or premixed water.

**Touch-free Operation Advantages:**

- Drastically reduces water consumption
- No physical contact. Helps to protect users against cross contamination
- Sensor settings adjustable by remote control

**Touch Operation Advantages:**

- Drastically reduces water consumption
- Non hold open feature
- More possibilities to save water: the water flow can be stopped in the middle of the cycle
- Stable and accurate water flow that can be changed on site



**Prox Sensors with Special Finishes**  
Touch-free prox sensor operation now available in a wide variety of special finishes to complete the interior design of your commercial restroom.

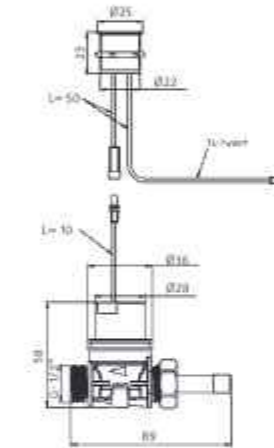

### APS KIT FOR FAUCET

Touch operation

Allows activation of the faucet/ unit once the users touch the designated area of the Piezo button. Water will shut off if the users touch the designated area again or once a factory set flow time of 8 seconds will pass.

- 07225008 APS KIT FOR FAUCET, 9V Battery / 9V Transformer (not included)

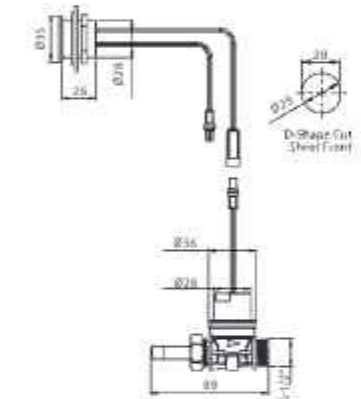

### PROX KIT FOR FAUCET

Touch-free prox operation

Allows automatic activation when the users bring their hands within the sensor range, and stops when the users remove their hands. IP67 including black battery box with 6AA 1.5V alkaline batteries

- 620200 PROX KIT FOR FAUCET, 9V Battery / 9V Transformer
- 620200 PROX KIT WITH DETACHABLE BODY FOR FAUCET 9V Battery / 9V Transformer



Prox Kit with detachable body for faucet

### WAVE KIT FOR FAUCET

Touch-free wave operation

Allows activation of the faucet/ unit once the users place their hands at a close proximity to the sensor.







Water will shut off if the users place their hands at a close proximity to the sensor again or once a factory set flow time of 8 seconds will pass.

The flow time is adjustable on site by remote control.

- 620400 WAVE KIT FOR FAUCET, 9V Battery / 9V Transformer
- 620400 WAVE KIT WITH DETACHABLE BODY FOR FAUCET 9V Battery / 9V Transformer



# SOAP DISPENSERS

	CSABA	49 - 50		GREEN / GREEN 28	63 - 64
	BOREAL	52		TUBULAR	65 - 68
	LOTUS TOPFILL	53		EXTREME CS	69 - 70
	QUADRAT DM	54		QUADRAT	71 - 72
	TRENDY	55 - 56		MULTIFEED KITS	73 - 76
	EXTREME	57 - 58		PROPRIETARY SOAP ADAPTOR KITS	77
	ELITE	59 - 61		SMARTBOX	78
	CLASSIC	62		TOUCH FREE HAND SANITIZER STANDS	79 - 80

**DRASTICALLY REDUCES**  
SOAP CONSUMPTION

**MATCHING FAUCET**

**EASY**  
TO INSTALL AND REFILL

**DESIGNED FOR HEAVY  
TRAFFIC LOCATIONS**  
100% BRASS BODY OR STAINLESS STEEL 316

**MAXIMIZED SAVINGS**  
TO BE USED WITH ANY NON-PROPRIETARY SOAP

**CROSS CONTAMINATION PROTECTION**  
NO PHYSICAL CONTACT

**CLOG AND  
BACKFLOW  
PREVENTION**

**SOAP DOSAGE ADJUSTABLE**  
BY REMOTE CONTROL



## CSABA SOAP DISPENSER

Deck-mounted touch-free electronic soap dispenser for non-proprietary soap

**Features:**

- Concealed IR sensor integrated into the spout
- Delivers liquid soap
- Peristaltic pump



1L

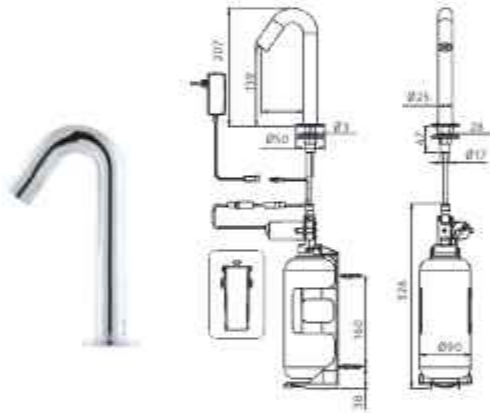

**CSABA SOAP DISPENSER**

- 233110 CSABA SOAP DISPENSER B, Battery box for six (6) D batteries
- 233100 CSABA SOAP DISPENSER E, 12V Transformer

TALL VERSION

**CSABA SOAP DISPENSER PLUS**

Tall version: 302mm body

- 233114 CSABA SD PLUS B, Battery box for six (6) D batteries
- 233106 CSABA SD PLUS E, 12V Transformer



**CSABA 6-PACK SOAP DISPENSER**

Includes:  
Six (6) liquid soap dispenser units  
one (1) remote control

- 233111 CSABA SD B 6-PACK, Battery box for six (6) D batteries
- 233101 CSABA SD E 6-PACK, 12V Transformer
- 233115 CSABA SD PLUS B 6-PACK, Battery box for six (6) D batteries
- 233107 CSABA SD PLUS E 6-PACK, 12V Transformer

6L

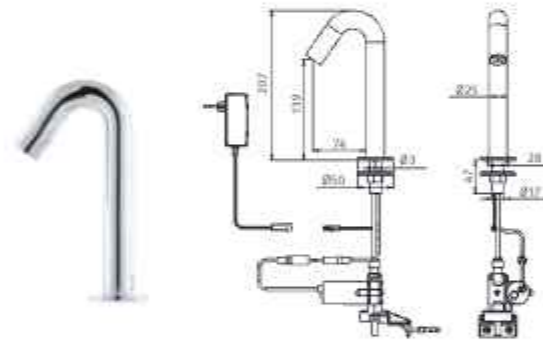

**MF CSABA SOAP DISPENSER**

Deck-mounted touch-free electronic soap dispenser to be used with Stern's Multifeed kits for multiple soap dispensers installation

- 07292288 MF CSABA SOAP DISPENSER, 12V Transformer

**CSABA SD 1.6 E**

Delivers liquid soap  
1.6 gallon (6L) tank kit for an individual soap dispenser

- 233102 CSABA SD 1.6 E, 12V Transformer



**NEW!**

## CSABA SOAP DISPENSER WITH SOAP LEVEL INDICATOR

Deck-mounted touch-free electronic soap dispenser for non-proprietary soap

**Features:**

- Soap level indicator shows green when soap tank is full, orange when soap level is low and red when the tank is empty
- Concealed IR sensor integrated into the spout
- Delivers liquid soap
- Peristaltic pump
- 1.6 US gallon (6L) soap tank



6L

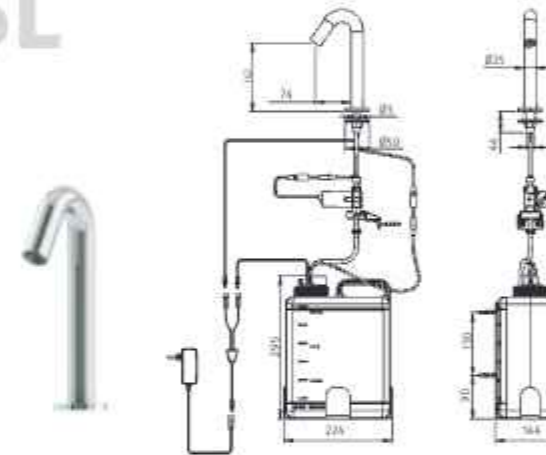

**CSABA SOAP DISPENSER WITH SOAP LEVEL INDICATOR**

- 233105 CSABA SOAP DISPENSER E WITH LEVEL INDICATOR, 12V Transformer





**NEW!**

## BOREAL SOAP DISPENSER

Deck-mounted touch-free electronic soap dispenser for non-proprietary soap

**Features:**

- Chrome plated brass body
- Delivers liquid/foam soap
- Peristaltic pump
- Adjustable settings



1L

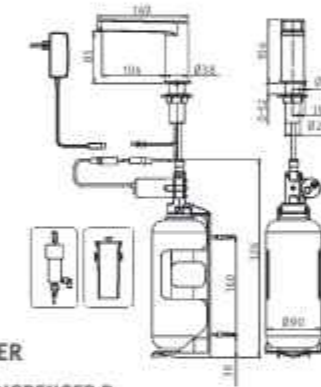

**BOREAL SOAP DISPENSER**

- 212100 BOREAL SOAP DISPENSER B, Battery box for six (6) D batteries
- 212105 BOREAL SOAP DISPENSER E, 12V Transformer

**BOREAL FOAM DISPENSER**

- 212130 BOREAL FD E, 12V Transformer



TALL VERSION

**BOREAL SOAP DISPENSER PLUS**

Tall version: 210 mm body

- 212110 BOREAL SD PLUS B, Battery box for six (6) D batteries
- 212115 BOREAL SD PLUS E, 12V Transformer



**BOREAL 6-PACK SOAP DISPENSER**

Includes: Six (6) liquid soap dispenser units  
One (1) remote control

- 212101 BOREAL SD B 6-PACK, Battery box for six (6) D batteries
- 212106 BOREAL SD E 6-PACK, 12V Transformer
- 212131 BOREAL FD E 6-PACK, 12V Transformer
- 212111 BOREAL SD PLUS B 6-PACK, Battery box for six (6) D batteries
- 212116 BOREAL SD PLUS E 6-PACK, 12V Transformer





## TRENDY SOAP DISPENSER

Deck-mounted touch-free electronic soap dispenser for non-proprietary soap

### Features:

- Chrome plated brass body
- Delivers liquid/foam soap
- Peristaltic pump
- Adjustable settings
- Tall version



## 1L

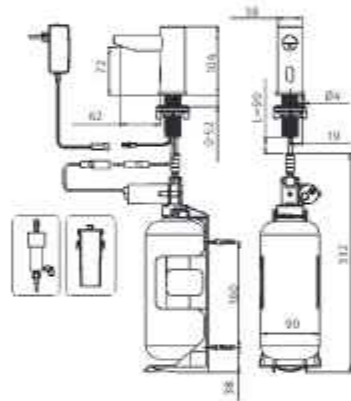

### TRENDY SOAP DISPENSER

- 239910 TRENDY SOAP DISPENSER B, Battery box for six (6) D batteries
- 239900 TRENDY SOAP DISPENSER E, 12V Transformer

### TRENDY FOAM DISPENSER

- 239930 TRENDY FOAM E, 12V Transformer

### TRENDY SOAP DISPENSER PLUS

Tall version: 304mm body

- 239910 TRENDY SOAP DISPENSER PLUS B, Battery box for six (6) D batteries
- 239900 TRENDY SOAP DISPENSER E PLUS, 12V Transformer



### TRENDY 6-PACK SOAP DISPENSER

Includes: Six (6) liquid soap dispenser units  
One (1) remote control

- 239911 TRENDY SD B 6-PACK, Battery box for six (6) D batteries
- 239901 TRENDY SD E 6-PACK, 12V Transformer
- 239931 TRENDY FOAM E 6-PACK, 12V Transformer
- 239913 TRENDY SD PLUS B 6-PACK, Battery box for six (6) D batteries
- 239903 TRENDY SD PLUS E 6-PACK, 12V Transformer

**NEW!**

## TRENDY SOAP DISPENSER WITH SOAP LEVEL INDICATOR

Deck-mounted touch-free electronic soap dispenser for non-proprietary soap

### Features:

- Soap level indicator shows green when soap tank is full, orange when soap level is low and red when the tank is empty
- Delivers liquid soap
- Concealed IR sensor integrated into the spout
- Peristaltic pump
- 1.6 US gallon (6L) soap tank



## 6L

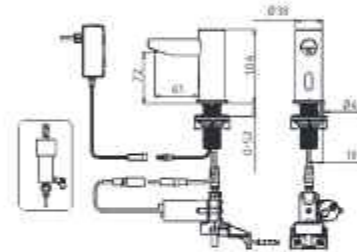

### MF TRENDY SOAP DISPENSER

Deck-mounted touch-free electronic soap/foam dispenser to be used with Stern's Multifeed kits for multiple soap dispensers installation

- 07292073 MF TRENDY SOAP DISPENSER, 12V Transformer
- 07292183 MF TRENDY FOAM DISPENSER, 12V Transformer
- 07292099 MF TRENDY SOAP DISPENSER PLUS, 12V Transformer

## 6L

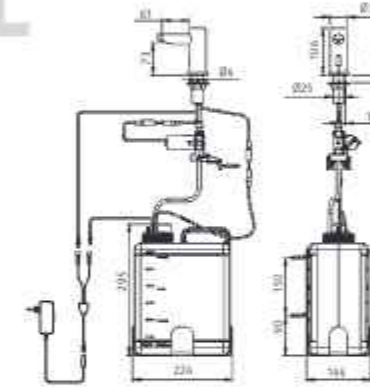

### TRENDY SOAP DISPENSER WITH LEVEL INDICATOR

- 239906 TRENDY SOAP DISPENSER WITH LEVEL INDICATOR, 12V Transformer



### TRENDY SD 1.6 E

1.6 gallon (6L) tank kit for an individual soap dispenser

- 239916 TRENDY SD 1.6 E, 12V Transformer



## EXTREME SOAP DISPENSER

Deck-mounted touch-free electronic soap dispenser for non-proprietary soap

### Features:

- Chrome plated brass body
- Delivers liquid soap
- Peristaltic pump
- Adjustable settings
- Tall version



## 1L

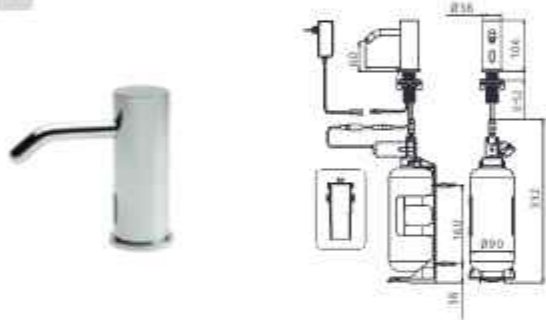

### EXTREME SOAP DISPENSER

- 237920 EXTREME SOAP DISPENSER B, Battery box for six (6) D batteries
- 237900 EXTREME SOAP DISPENSER E, 12V Transformer

### EXTREME SOAP DISPENSER PLUS

Tall version: 304 mm body

- 237922 EXTREME SOAP DISPENSER PLUS B, Battery box for six (6) D batteries
- 237905 EXTREME SOAP DISPENSER PLUS E, 12V Transformer



## 6L



### MF EXTREME SOAP DISPENSER

Deck-mounted touch-free electronic soap dispenser to be used with Stern's Multifeed kits for multiple soap dispensers installation

- 07292056 MF EXTREME SOAP DISPENSER, 12V Transformer
- 07292095 MF EXTREME SOAP DISPENSER PLUS, 12V Transformer

### EXTREME 6-PACK SOAP DISPENSER

Includes: Six (6) liquid soap dispenser units  
One (1) remote control

- 237921 EXTREME SD B 6-PACK, Battery box for six (6) D batteries
- 237901 EXTREME SD E 6-PACK, 12V Transformer
- 237923 EXTREME SD PLUS B 6-PACK, Battery box for six (6) D batteries
- 237906 EXTREME SD PLUS E 6-PACK, 12V Transformer

### EXTREME SD 1.6 E

1.6 gallon (6L) tank kit for an individual soap dispenser

- 237916 EXTREME SD 1.6 E, 12V Transformer



**NEW!**

## EXTREME SOAP DISPENSER WITH SOAP LEVEL INDICATOR

Deck-mounted touch-free electronic soap dispenser for non-proprietary soap

### Features:

- Soap level indicator shows green when soap tank is full, orange when soap level is low and red when the tank is empty
- Delivers liquid soap
- Peristaltic pump
- 1.6 US gallon (6L) soap tank



## 6L

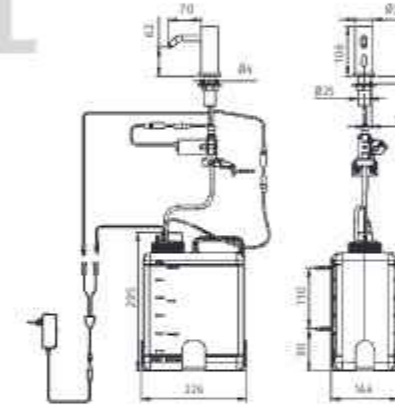

### EXTREME SOAP DISPENSER WITH LEVEL INDICATOR

- 237917 EXTREME SOAP DISPENSER WITH LEVEL INDICATOR, 12V Transformer



## ELITE SOAP DISPENSER

Deck-mounted touch-free electronic soap dispenser for non-proprietary soap

### Features:

- Chrome plated brass body
- Delivers liquid/foam soap
- Peristaltic pump
- Adjustable settings
- Tall version



## ELITE SOAP DISPENSER AISI316

Deck-mounted touch-free electronic soap dispenser for non-proprietary soap

### Features:

- Stainless Steel AISI316 body
- Delivers liquid/foam soap
- Peristaltic pump
- Adjustable settings
- Tall version



# 1L



### ELITE SOAP DISPENSER

- 236110 ELITE SOAP DISPENSER B, Battery box for six (6) D batteries
- 236100 ELITE SOAP DISPENSER E, 12V Transformer

### ELITE FOAM DISPENSER

- 236120 ELITE FOAM E, 12V Transformer

### TALL VERSION ELITE SOAP DISPENSER PLUS

Tall version: 285mm body

- 236107 ELITE SOAP DISPENSER PLUS B, Battery box for six (6) D batteries
- 236105 ELITE SOAP DISPENSER PLUS E PLUS, 12V Transformer



# 6L

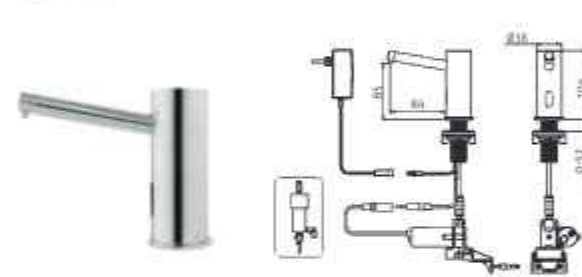

### MF ELITE SOAP DISPENSER

Deck-mounted touch-free electronic soap/foam dispenser to be used with Stern's Multifeed kits for multiple soap dispensers installation

- 07292077 MF ELITE SOAP DISPENSER, 12V Transformer
- 07292205 MF ELITE FOAM DISPENSER, 12V Transformer
- 07292093 MF ELITE SOAP DISPENSER PLUS, 12V Transformer

# 1L



### ELITE SOAP DISPENSER AISI316

- 236113 ELITE SOAP DISPENSER B AISI316, Battery box for six (6) D batteries
- 236103 ELITE SOAP DISPENSER E AISI316, 12V Transformer

### ELITE FOAM DISPENSER AISI316

- 236122 ELITE FOAM E AISI316, 12V Transformer

### TALL VERSION ELITE SOAP DISPENSER PLUS AISI316

Tall version: 289mm body

- 236109 ELITE SOAP DISPENSER PLUS B AISI316, Battery box for six (6) D batteries
- 236104 ELITE SOAP DISPENSER PLUS E AISI316, 12V Transformer

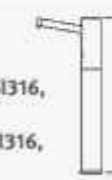

# 6L



### MF ELITE SOAP DISPENSER AISI316

Deck-mounted touch-free electronic soap/foam dispenser to be used with Stern's Multifeed kits for multiple soap dispensers installation

- 07292239 MF ELITE SOAP DISPENSER AISI316, 12V Transformer
- 07292240 MF ELITE FOAM DISPENSER AISI316, 12V Transformer
- 07292241 MF ELITE SOAP PLUS AISI316, 12V Transformer

### ELITE 6-PACK SOAP DISPENSER

Includes: Six (6) liquid soap dispenser units  
One (1) remote control

- 236111 ELITE SD B 6-PACK, Battery box for six (6) D batteries
- 236101 ELITE SD E 6-PACK, 12V Transformer
- 236121 ELITE FOAM E 6-PACK, 12V Transformer
- 236108 ELITE SD PLUS B 6-PACK, Battery box for six (6) D batteries
- 236106 ELITE SD PLUS E 6-PACK, 12V Transformer

### ELITE SD 1.6 E

1.6 gallon (6L) tank kit for an individual soap dispenser

- 236216 ELITE SD 1.6 E, 12V Transformer



### ELITE 6-PACK SOAP DISPENSER

Includes: Six (6) liquid soap dispenser units  
One (1) remote control

- 236114 ELITE SD B 6-PACK AISI316, Battery box for six (6) D batteries
- 236117 ELITE SD E 6-PACK AISI316, 12V Transformer
- 236123 ELITE FOAM E 6-PACK AISI316, 12V Transformer
- 236109 ELITE SD PLUS B 6-PACK AISI316, Battery box for six (6) D batteries
- 236104 ELITE SD PLUS E 6-PACK AISI316, 12V Transformer

### ELITE SD 1.6 E AISI316

1.6 gallon (6L) tank kit for an individual soap dispenser

- 236216 ELITE SD 1.6 E AISI316, 12V Transformer



## ELITE SOAP DISPENSER WITH SOAP LEVEL INDICATOR

Deck-mounted touch-free electronic soap dispenser for non-proprietary soap

**Features:**

- Soap level indicator shows green when soap tank is full, orange when soap level is low and red when a refill is needed
- Delivers liquid soap
- Peristaltic pump
- 1.6 US gallon (6L) soap tank



6L

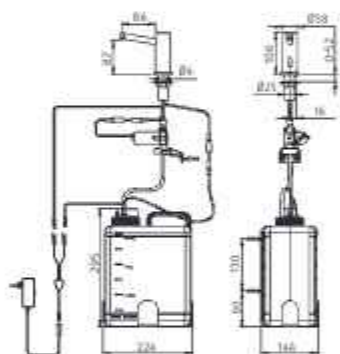

### ELITE SOAP DISPENSER WITH LEVEL INDICATOR

- 236131 ELITE SOAP DISPENSER WITH LEVEL INDICATOR, 12V Transformer



## CLASSIC SOAP DISPENSER

Deck-mounted touch-free electronic soap dispenser for non-proprietary soap

**Features:**

- Chrome plated brass body
- Delivers liquid/foam soap
- Peristaltic pump
- Concealed IR sensor integrated into the spout
- Adjustable settings



1L



### CLASSIC SOAP DISPENSER

- 292400 CLASSIC SOAP DISPENSER B, Battery box for six (6) D batteries
- 292410 CLASSIC SOAP DISPENSER E, 12V Transformer

### CLASSIC FOAM DISPENSER

- 292300 CLASSIC FOAM E, 12V Transformer

6L

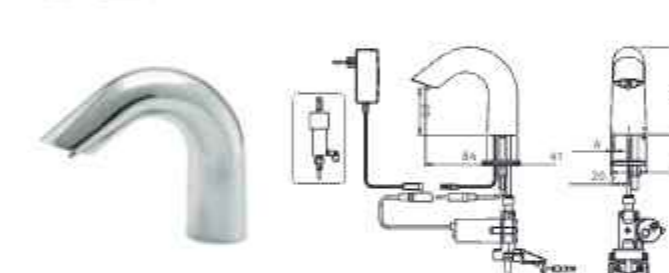

### MF CLASSIC SOAP DISPENSER

- Deck-mounted touch-free electronic soap/foam dispenser to be used with Stern's Multifeed kits for multiple soap dispensers installation
- 07292177 MF CLASSIC SOAP DISPENSER, 12V Transformer
  - 07292207 MF CLASSIC FOAM DISPENSER, 12V Transformer

### CLASSIC 6-PACK SOAP DISPENSER

Includes: Six (6) liquid soap dispenser units  
One (1) remote control

- 292401 CLASSIC SD B 6-PACK, Battery box for six (6) D batteries
- 292411 CLASSIC SD E 6-PACK, 12V Transformer
- 292301 CLASSIC FOAM E 6-PACK, 12V Transformer

### CLASSIC SD 1.6 E

1.6 gallon (6L) tank kit for an individual soap dispenser

- 292416 CLASSIC SD 1.6 E, 12V Transformer



## GREEN SOAP DISPENSER

Deck-mounted touch-free electronic soap dispenser for non-proprietary soap

**Features:**

- Chrome plated brass body
- Delivers liquid/foam soap
- Peristaltic pump
- Adjustable settings



## GREEN 28 SOAP DISPENSER

Deck-mounted touch-free electronic soap dispenser for non-proprietary soap

**Features:**

- Chrome plated brass body
- Delivers liquid/foam soap
- Peristaltic pump
- Adjustable settings



1L

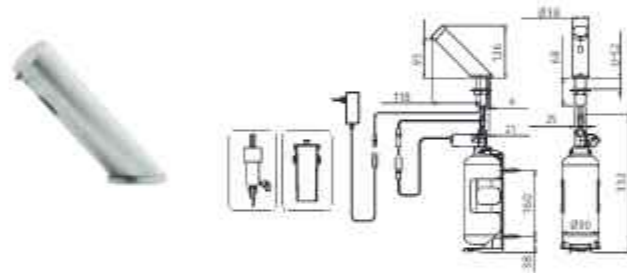

**GREEN SOAP DISPENSER**

Includes a brass base for extra protection in high traffic locations

- 225845 GREEN SOAP DISPENSER B, Battery box for six (6) D batteries
- 225840 GREEN SOAP DISPENSER E, 12V Transformer

**GREEN FOAM DISPENSER**

Includes a brass base for abuse protection in high traffic locations

- 225842 GREEN FOAM E, 12V Transformer

6L

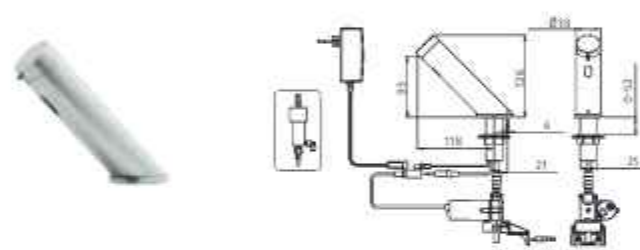

**MF GREEN SOAP DISPENSER**

Deck-mounted touch-free electronic soap/foam dispenser to be used with Stern's Multifeed kits for multiple soap dispensers installation

- 07292062 MF GREEN SOAP DISPENSER, 12V Transformer
- 07292228 MF GREEN FOAM DISPENSER, 12V Transformer



1L

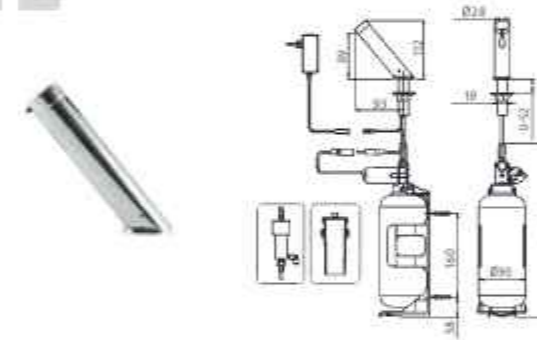

**GREEN 28 SOAP DISPENSER**

Includes a brass base for extra protection in high traffic locations

- 352900 GREEN 28 SOAP DISPENSER B, Battery box for six (6) D batteries
- 352910 GREEN 28 SOAP DISPENSER E, 12V Transformer

**GREEN 28 FOAM DISPENSER**

Includes a brass base for extra protection in high traffic locations

- 352920 GREEN 28 FOAM E, 12V Transformer

6L

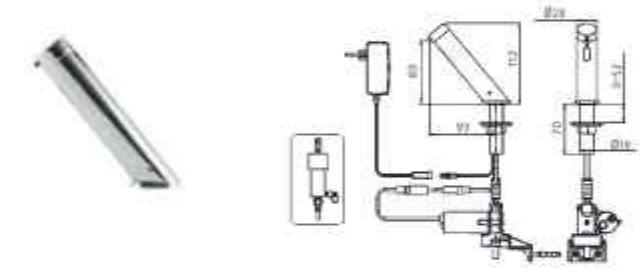

**MF GREEN 28 SOAP DISPENSER**

Deck-mounted touch-free electronic soap/foam dispenser to be used with Stern's Multifeed kits for multiple soap dispensers installation

- 07292155 MF GREEN 28 SOAP DISPENSER, 12V Transformer
- 07292206 MF GREEN F28 FOAM DISPENSER, 12V Transformer

**GREEN 6-PACK SOAP DISPENSER**

Includes: Six (6) liquid soap dispenser units  
One (1) remote control

- 225846 GREEN SD B 6-PACK, Battery box for six (6) D batteries
- 225841 GREEN SD E 6-PACK, 12V Transformer
- 225843 GREEN FOAM E 6-PACK, 12V Transformer

**GREEN SD 1.6 E**

1.6 gallon (6L) tank kit for an individual soap dispenser

- 225816 GREEN SD 1.6 E, 12V Transformer



**GREEN 6-PACK SOAP DISPENSER**

Includes: Six (6) liquid soap dispenser units  
One (1) remote control

- 352901 GREEN 28 SD B 6-PACK, Battery box for six (6) D batteries
- 352911 GREEN 28 SD E 6-PACK, 12V Transformer
- 352921 GREEN 28 FOAM E 6-PACK, 12V Transformer

**GREEN 28 SD 1.6 E**

1.6 gallon (6L) tank kit for an individual soap dispenser

- 352916 GREEN 28 SD 1.6 E, 12V Transformer



# TUBULAR SOAP DISPENSER

Wall-mounted touch-free electronic soap dispenser for non-proprietary soap

**Features:**

- Chrome plated brass body
- Delivers liquid/foam soap
- Peristaltic pump
- Adjustable settings



1L

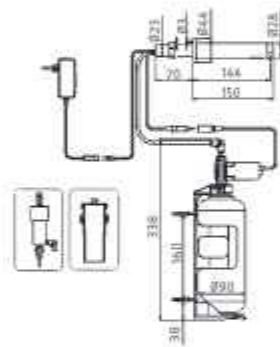

**TUBULAR SOAP DISPENSER**

Installation in dry walls  
Optional version: 120mm

- 350920 TUBULAR SOAP DISPENSER B, Battery box for six (6) D batteries
- 350925 TUBULAR SOAP DISPENSER E, 12V Transformer

**TUBULAR FOAM DISPENSER**

Optional version: 120mm

- 350980 TUBULAR FOAM E, 12V Transformer

6L

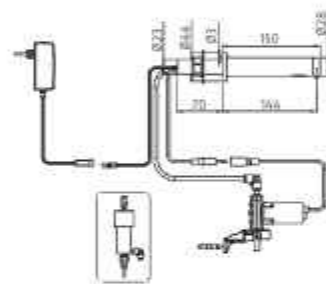

**MF TUBULAR SOAP DISPENSER**

Wall-mounted touch-free electronic soap dispenser to be used with Stern's Multifeed kits for multiple soap dispensers installation  
Installation in dry walls

Optional version: 120mm

- 07292076 MF TUBULAR SOAP DISPENSER, 12V Transformer
- 07292186 MF TUBULAR FOAM DISPENSER, 12V Transformer

1L

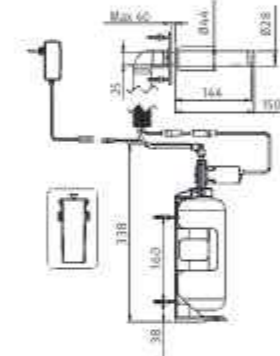

**TUBULAR SOAP DISPENSER 2030**

Concealed installation in concrete or brick walls  
Optional version: 120mm

Chrome-plated 100% brass spout

- 350922 TUBULAR SOAP DISPENSER 2030 B, Battery box for six (6) D batteries
- 350927 TUBULAR SOAP DISPENSER 2030 E, 12V Transformer

6L

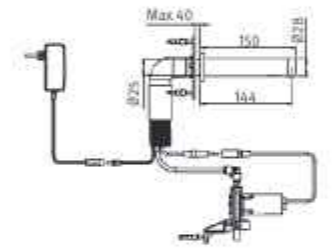

**MF TUBULAR SOAP DISPENSER 2030**

Wall-mounted touch-free electronic soap dispenser to be used with Stern's Multifeed kits for multiple soap dispensers installation  
Concealed installation in concrete or brick walls

Optional version: 120mm

- 07292081 MF TUBULAR SOAP DISPENSER 2030, 12V Transformer

**TUBULAR 6-PACK SOAP DISPENSER**

Includes: Six (6) liquid soap dispenser units  
One (1) remote control

- 350921 TUBULAR SD B 6-PACK, Battery box for six (6) D batteries
- 350926 TUBULAR SD E 6-PACK, 12V Transformer
- 350981 TUBULAR FOAM E 6-PACK, 12V Transformer

**TUBULAR SD 1.6 E**

1.6 gallon (6L) tank kit for an individual soap dispenser

- 350116 TUBULAR SD 1.6 E, 12V Transformer



**TUBULAR 2030 6-PACK SOAP DISPENSER**

Includes: Six (6) liquid soap dispenser units  
One (1) remote control

- 350923 TUBULAR 2030 SD B 6-PACK, Battery box for six (6) D batteries
- 350928 TUBULAR 2030 SD E 6-PACK, 12V Transformer

**TUBULAR 2030 SD 1.6 E**

1.6 gallon (6L) tank kit for an individual soap dispenser

- 350816 TUBULAR 2030 SD 1.6 E, 12V Transformer



## TUBULAR SOAP DISPENSER AISI316

Wall-mounted touch-free electronic soap dispenser for non-proprietary soap

### Features:

- Stainless Steel AISI316 product body
- Delivers liquid/foam soap
- Peristaltic pump
- Adjustable settings



# 1L

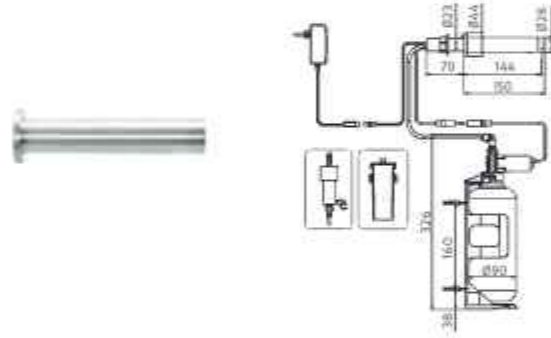

### TUBULAR SOAP DISPENSER AISI316

Installation in dry walls

Optional version: 120mm

- 350919 TUBULAR SOAP DISPENSER AISI316 B, Battery box for six (6) D batteries
- 350924 TUBULAR SOAP DISPENSER AISI316 E, 12V Transformer

### TUBULAR FOAM DISPENSER AISI316

Installation in dry walls

- 350982 TUBULAR FOAM E AISI316, 12V Transformer

### TUBULAR SD AISI 316 6-PACK

Includes: Six (6) liquid soap dispenser units  
One (1) remote control

- 350991 TUBULAR SD AISI 316 B 6-PACK, Battery box for six (6) D batteries
- 350984 TUBULAR SD AISI 316 E 6-PACK, 12V Transformer
- 350983 TUBULAR FOAM E AISI 316 6-PACK, 12V Transformer

# 6L

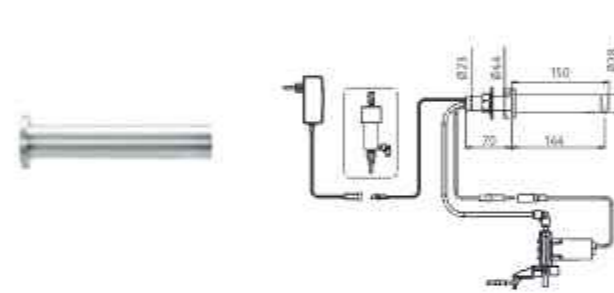

### MF TUBULAR SOAP DISPENSER AISI316

To be used with Stern's Multifeed kits for multiple soap dispensers installation

Installation in dry walls

Optional version: 120mm

- 07292221 MF TUBULAR SOAP DISPENSER AISI316, 12V Transformer
- 07292231 MF TUBULAR FOAM DISPENSER AISI316, 12V Transformer

### TUBULAR SD 1.6 E AISI 316

1.6 gallon (6L) tank kit for an individual soap dispenser

- 350932 TUBULAR SD 1.6 E AISI 316, 12V Transformer



# 1L

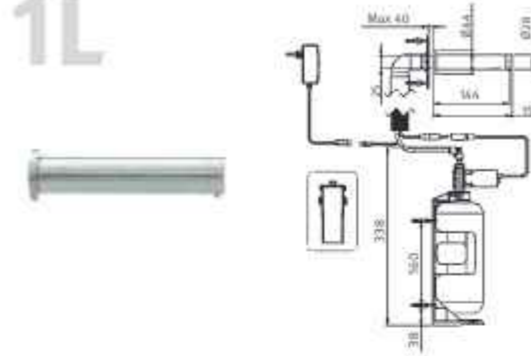

### TUBULAR SOAP DISPENSER 2030 AISI316

Concealed installation in concrete or brick walls

Optional version: 120mm

- 350918 TUBULAR SD 2030 B AISI316, Battery box for six (6) D batteries
- 350917 TUBULAR SD 2030 E AISI316, 12V Transformer

# 6L

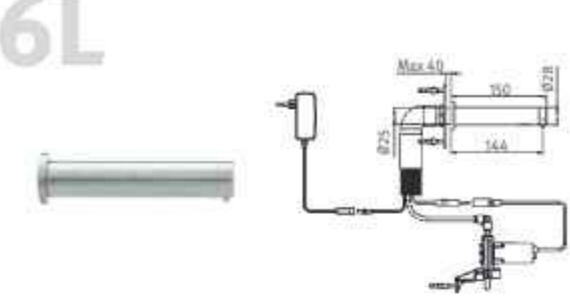

### MF TUBULAR SOAP DISPENSER 2030 AISI316

To be used with Stern's Multifeed kits for multiple soap dispensers installation

Concealed installation in concrete or brick walls

Optional version: 120mm

- 07292222 MF TUBULAR SOAP DISPENSER 2030 AISI316, 12V Transformer



### TUBULAR 2030 6-PACK SOAP DISPENSER AISI 316

Includes: Six (6) liquid soap dispenser units  
One (1) remote control

- 350992 TUBULAR SD 2030B AISI316 6-PACK, Battery box for six (6) D batteries
- 350933 TUBULAR SD 2030E AISI316 6-PACK, 12V Transformer

### TUBULAR 2030 SD 1.6 E AISI 316

1.6 gallon (6L) tank kit for an individual soap dispenser

- 350916 TUBULAR 2030 SD 1.6 E AISI316, 12V Transformer





# EXTREME CS SOAP DISPENSER

Wall-mounted touch-free electronic soap dispenser for non-proprietary soap

**Features:**

- Concealed sensor integrated into the spout
- Delivers liquid soap
- Peristaltic pump
- Adjustable settings
- Stainless steel AISI316 spout available



STAINLESS STEEL AISI316

1L



**EXTREME CS SOAP DISPENSER**

Installation in dry walls

- 237891 **EXTREME CS SOAP DISPENSER B**, Battery box for six (6) D batteries
- 237890 **EXTREME CS SOAP DISPENSER E**, 12V Transformer

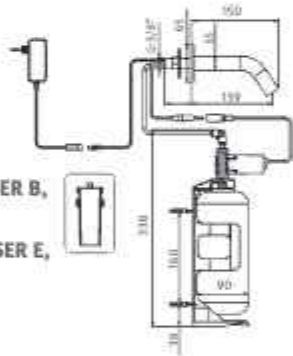

**EXTREME CS SD 2030**

Concealed installation in concrete or brick walls

- 237896 **EXTREME CS SD 2030 B**, Battery box for six (6) D batteries
- 237892 **EXTREME CS SD 2030 E**, 12V Transformer

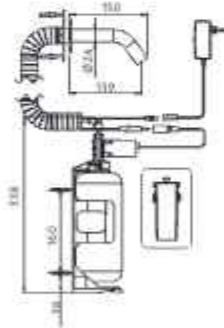

6L



**MF EXTREME CS SOAP DISPENSER**

To be used with Stern's Multifeed kits for multiple soap dispensers installation  
Installation in dry walls

- 07292271 **MF EXTREME CS SD E**, 12V Transformer

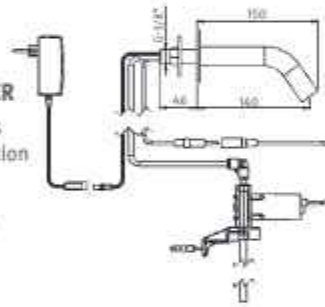

**MF EXTREME CS SD 2030**

To be used with Stern's Multifeed kits for multiple soap dispensers installation  
Concealed installation in concrete or brick walls

- 07292290 **MF EXTREME SOAP DISPENSER 2030**, 12V Transformer

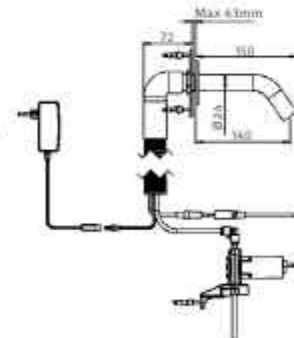

1L



**EXTREME CS SOAP DISPENSER AISI316**

Installation in dry walls

- 237891-316 **EXTREME CS SOAP DISPENSER B AISI316**, Battery box for six (6) D batteries
- 237890-316 **EXTREME CS SOAP DISPENSER E AISI316**, 12V Transformer

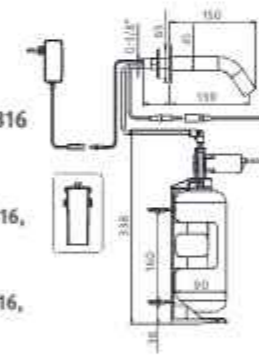

**EXTREME CS SD 2030 AISI316**

Concealed installation in concrete or brick walls

- 237896-316 **EXTREME CS SD 2030 B AISI316**, Battery box for six (6) D batteries
- 237892-316 **EXTREME CS SD 2030 E AISI316**, 12V Transformer

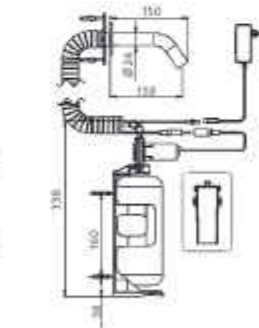

6L



**MF EXTREME CS SD AISI316**

To be used with Stern's Multifeed kits for multiple soap dispensers installation  
Installation in dry walls

- 07292285 **MF EXTREME CS SD E AISI316**, 12V Transformer

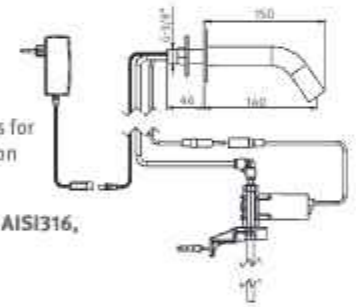

**MF EXTREME CS SD 2030 AISI316**

To be used with Stern's Multifeed kits for multiple soap dispensers installation  
Concealed installation in concrete or brick walls

- 07292286 **MF EXTREME SD 2030 AISI316**, 12V Transformer

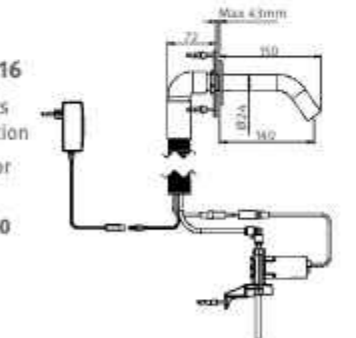

**EXTREME CS 6-PACK SOAP DISPENSER**

Includes: Six (6) liquid soap dispenser units  
One (1) remote control

- 237894 **EXTREME CS SD B 6-PACK**, Battery box for six (6) D batteries
- 237893 **EXTREME CS SD E 6-PACK**, 12V Transformer
- 237897 **EXTREME CS 2030 SD B 6-PACK**, Battery box for six (6) D batteries
- 237895 **EXTREME CS 2030 SD E 6-PACK**, 12V Transformer

**EXTREME CS SD 1.6 E**

1.6 gallon (6L) tank kit for an individual soap dispenser

- 237882 **EXTREME CS SD 1.6 E**, 12V Transformer
- 237884 **EXTREME CS 2030 SD 1.6 E**, 12V Transformer

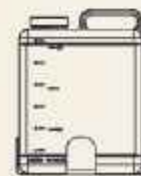

**EXTREME CS AISI316 6-PACK SOAP DISPENSER**

Includes: Six (6) liquid soap dispenser units  
One (1) remote control

- 237898 **EXTREME CS SD B AISI316 6-PACK**, Battery box for six (6) D batteries
- 237899 **EXTREME CS SD E AISI316**, 12V Transformer
- 237880 **EXTREME CS SD 2030 B AISI316 6-PACK**, Battery box for six (6) D batteries
- 237881 **EXTREME CS SD 2030E AISI316 6-PACK**, 12V Transformer

**EXTREME CS SD AISI316 1.6 E**

1.6 gallon (6L) tank kit for an individual soap dispenser

- 237885 **EXTREME CS SD AISI316 1.6 E**, 12V Transformer
- 237883 **EXTREME CS 2030 SD AISI316 1.6 E**, 12V Transformer



# QUADRAT SOAP DISPENSER

Wall-mounted touch-free electronic soap dispenser for non-proprietary soap

**Features:**

- 100% heavy-duty one piece brass body
- Delivers liquid soap
- Chrome plated brass body
- Peristaltic pump
- Adjustable settings



1L

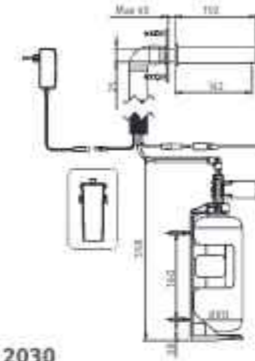

**QUADRAT SOAP DISPENSER 2030**

Concealed installation in concrete or brick walls

- 351920 QUADRAT SOAP DISPENSER 2030 B, Battery box for six (6) D batteries
- 351930 QUADRAT SOAP DISPENSER 2030 E, 12V Transformer

6L

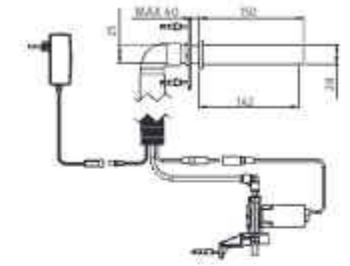

**MF QUADRAT SOAP DISPENSER 2030**

To be used with Stern's Multifeed kits for multiple soap dispensers installation

- 07292094 MF QUADRAT SOAP DISPENSER 2030, 12V Transformer

1L

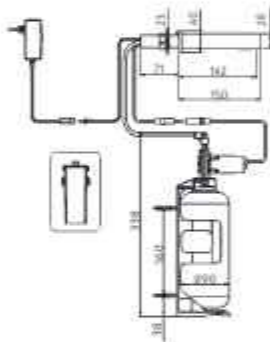

**QUADRAT SOAP DISPENSER**

Installation in dry walls

- 351910 QUADRAT SOAP DISPENSER B, Battery box for six (6) D batteries
- 351900 QUADRAT SOAP DISPENSER E, 12V Transformer

6L

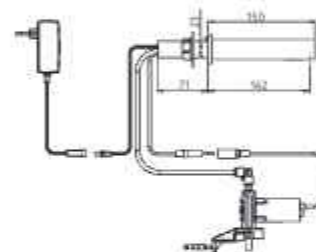

**MF QUADRAT SOAP DISPENSER**

To be used with Stern's Multifeed kits for multiple soap dispensers installation

Installation in dry walls

- 07292078 MF QUADRAT SOAP DISPENSER, 12V Transformer



**QUADRAT 6-PACK SOAP DISPENSER**

Includes: Six (6) liquid soap dispenser units  
One (1) remote control

- 351911 QUADRAT SD B 6-PACK, Battery box for six (6) D batteries
- 351901 QUADRAT SD E 6-PACK, 12V Transformer

**QUADRAT SD 1.6 E**

1.6 gallon (6L) tank kit for an individual soap dispenser

- 351916 QUADRAT SD 1.6 E, 12V Transformer



**QUADRAT 2030 6-PACK SOAP DISPENSER**

Includes: Six (6) liquid soap dispenser units  
One (1) remote control

- 351921 QUADRAT 2030 SD B 6-PACK, Battery box for six (6) D batteries
- 351931 QUADRAT 2030 SD E 6-PACK, 12V Transformer

**QUADRAT 2030 SD 1.6 E**

1.6 gallon (6L) tank kit for an individual soap dispenser

- 351316 QUADRAT 2030 SD 1.6 E, 12V Transformer



# MULTIFEED KITS

Installation kit for more efficient maintenance of multiple soap dispensers. Saves time and money, can supply up to six soap dispensers from one large capacity 1.6 gallon (6L) tank. Ideal for high traffic areas with multiple hand washing stations in high traffic restrooms. Enables productive refill of multiple soap dispensers through a single top fill unit above deck and an LED indicator that lets maintenance staff know when soap levels are low. Suitable for any foam or liquid soap with the recommended viscosity.

### Features:

- Allows multiple soap dispensers installation (up to six (6) dispensers) with a single 1.6 US gallon (6L) tank
- Stainless Steel tank support or lockable underbasin cabinet

### Options:

- Anti-theft top filling brass mechanism for easy refill from the counter top
- Soap level indicator
- Below deck filling mechanism
- **NEW:** Plywood HPL (High Pressure Laminate) lockable cabinet with level indicator window. White panel and oak style frame for 1.6 Gallon (6L) soap tank with option to house the 33.8 FL OZ (1L) soap bottle as necessary. Hides unsightly pipes and connectors from the view of users.

### Advantages:

- Drastically reduces soap consumption
- Cross contamination protection - no physical contact
- Maximized savings - can be used with any non-proprietary soap
- Easy installation
- Fast and simple refill with optional LED indication of soap level
- Highly durable - with optional vandal-resistant top-filling mechanism



## TOP-FILLING MULTIFEED KIT WITH SOAP LEVEL INDICATOR

- Vandal-resistant chrome-plated top-filling brass mechanism. LED soap level indicator.
- Power splitter for connection to transformer powered MF soap dispenser.
- Stainless steel tank support.

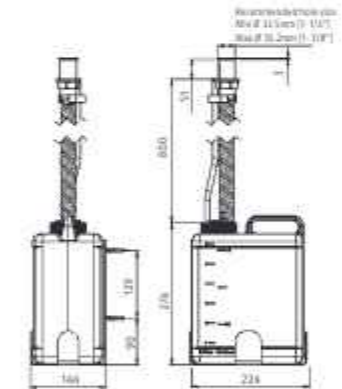
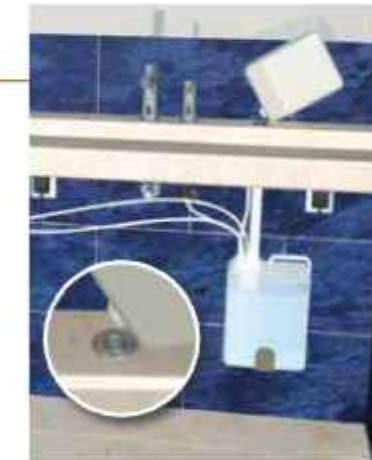

- 07220152  
Top-Filling Multifeed Kit with Soap Level Indicator

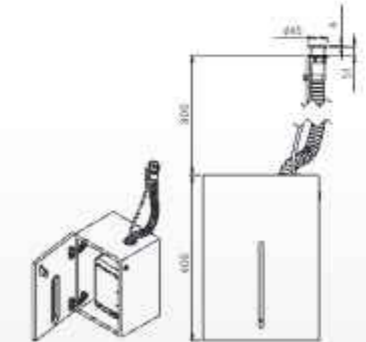

- 07220152CB  
Top-Filling Multifeed Kit with Soap Level Indicator and lockable cabinet

### TOP-FILLING MULTIFEED KIT

Vandal-resistant chrome-plated top-filling brass mechanism.  
Available for transformer powered MF soap dispensers.  
With lockable cabinet.

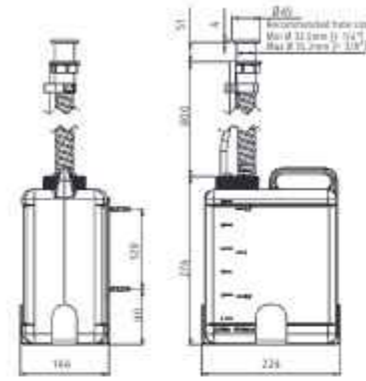

• 07220090  
Top-Filling Multifeed Kit

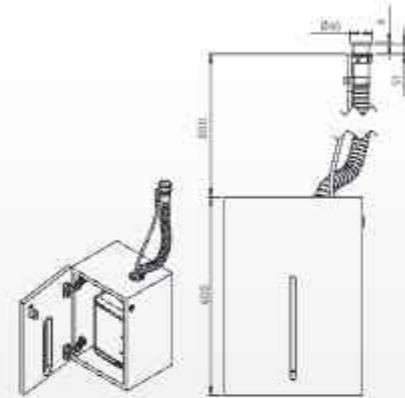

• 07220090CB  
Top-Filling Multifeed With lockable cabinet

### BELOW DECK MULTIFEED KIT

Vandal-resistant chrome-plated top-filling brass mechanism.  
Available for transformer powered MF soap dispensers.  
With lockable cabinet.

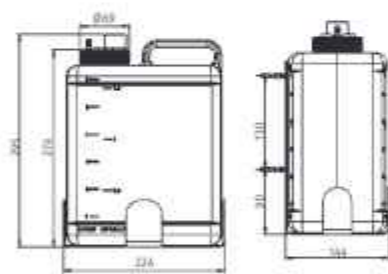

• 07220096  
Below Deck Multifeed Kit

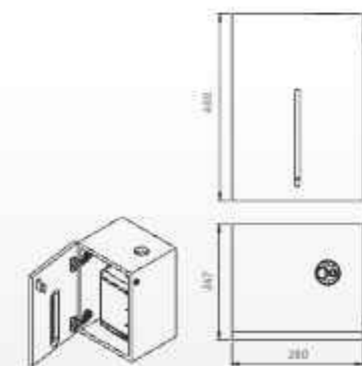

• 07220096CB  
Below Deck Multifeed Kit With lockable cabinet

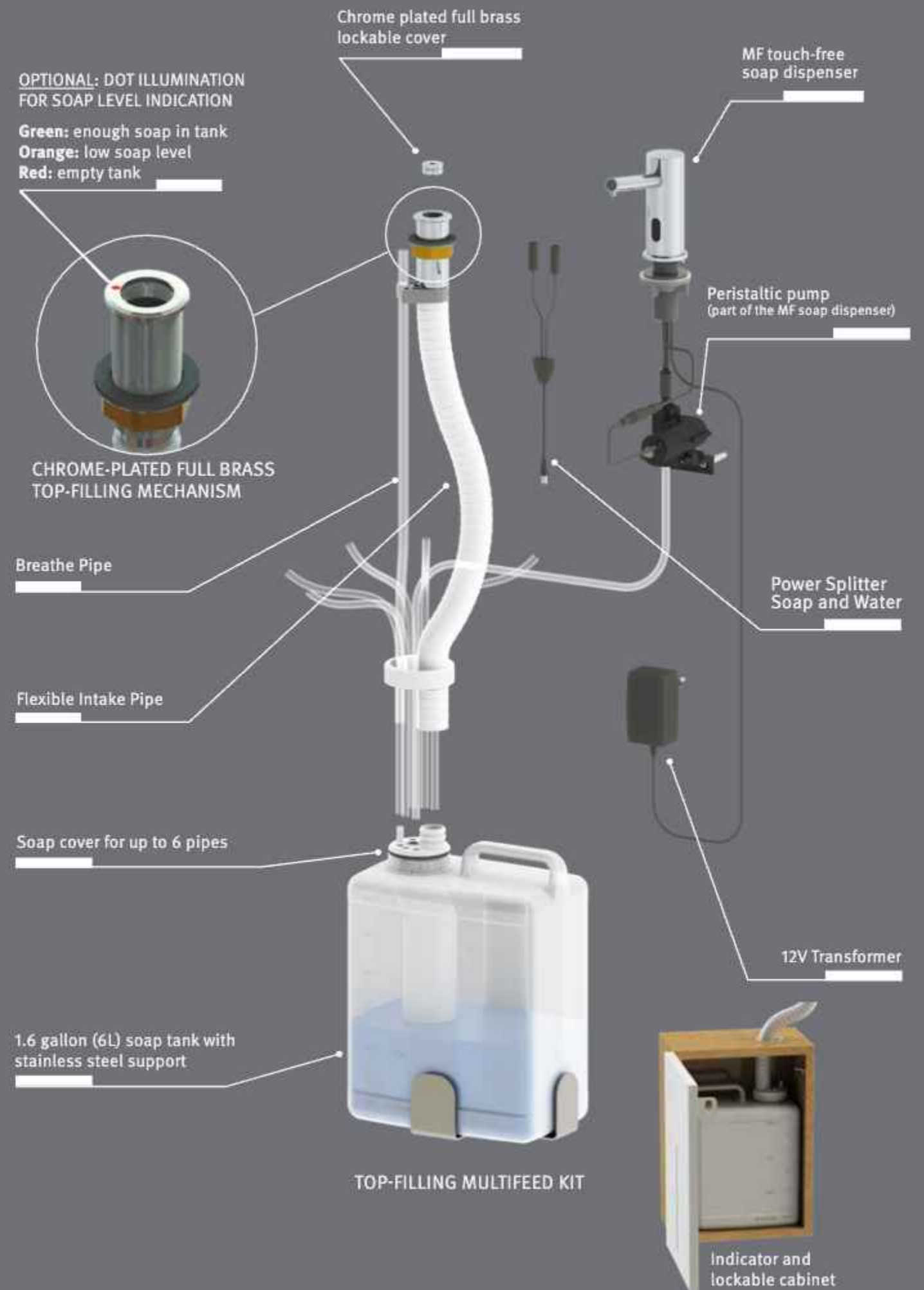

**NEW!**

## PROPRIETARY SOAP ADAPTOR KITS

Just choose the adaptor that fits your soap container and fit it to the opening of your choice of soap container. Insert the pipe into the hole in the cap, attach the quick connector to the pipe, and voilà! Your Stern soap dispenser is ready to use your selected soap.

Ordering information at page 146

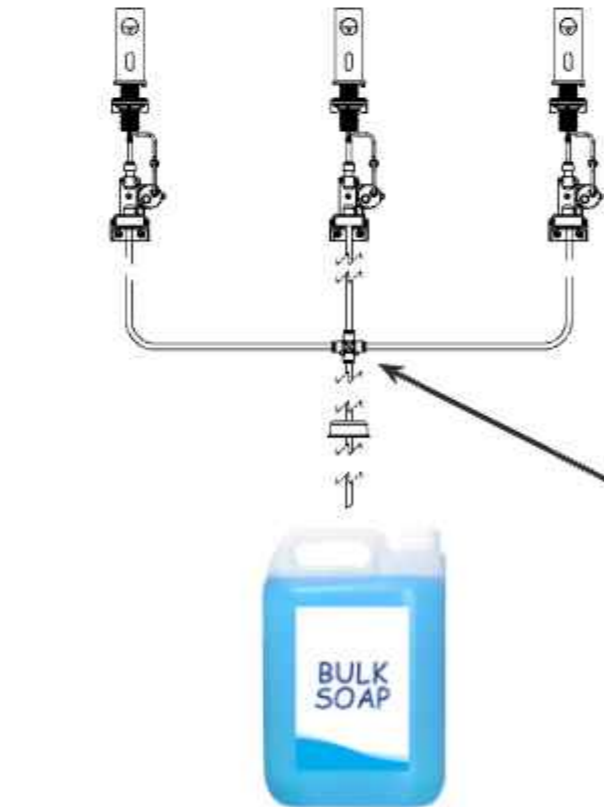

Option to connect up to 3 soap dispensers



## SMARTBOX 2LE

**Touch-free hand sanitizer dispenser for wall-mounted installations**  
Activated by an infrared sensor located in the base. For use with any non-proprietary hand sanitizer gel of the recommended viscosity.

**Features:**

- Stainless Steel AISI316 body
- Delivers non-proprietary hand sanitizer
- Peristaltic pump
- Adjustable settings

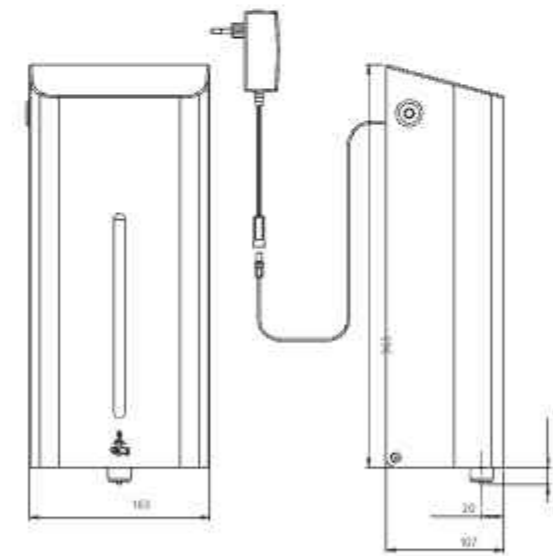

# 2L

### SMARTBOX 2L

- 280222 SMARTBOX 2LE, 12V Transformer



## TOUCH FREE HAND SANITIZER STATION

Touch-free electronic hand sanitizer stand for deck or wall mounted installations with dripless automatic shutoff. Suitable for supermarkets, banks, lobbies and any high traffic public areas.

### Features:

- 100% heavy-duty one piece brass body
- Delivers non-proprietary hand sanitizer
- Chrome plated brass body dispenser
- Peristaltic pump
- Adjustable settings



# 6L

- **233200 CSABA WM HAND SANITIZER STATION**  
Battery box for six (6) D batteries /12V Transformer

## TOUCH FREE HAND SANITIZER STAND

Stern's touch-free hand sanitizer dispenser stands are stand-alone, deck mounted units recommended for supermarkets, banks, lobbies, and any high traffic public areas.

### Features:

- 100% heavy-duty one piece brass body
- Delivers non-proprietary hand sanitizer
- Chrome plated brass body dispenser
- Power Supply: Battery box for six (6) D batteries or 12V transformer
- Peristaltic pump
- Adjustable settings



# 1L

### TOUCH FREE HAND SANITIZER STAND 1L

- **28100CS1B CSABA TOUCH FREE HAND SANITIZER STAND 1L**  
Battery box for six (6) D batteries
- **28100CS1E CSABA TOUCH FREE HAND SANITIZER STAND 1L**  
12V Transformer

# 6L

### TOUCH FREE HAND SANITIZER STAND 6L

- **28100CS6B CSABA TOUCH FREE HAND SANITIZER STAND 6L**  
Battery box for six (6) D batteries
- **28100CS6E CSABA TOUCH FREE HAND SANITIZER STAND 6L**  
12V Transformer

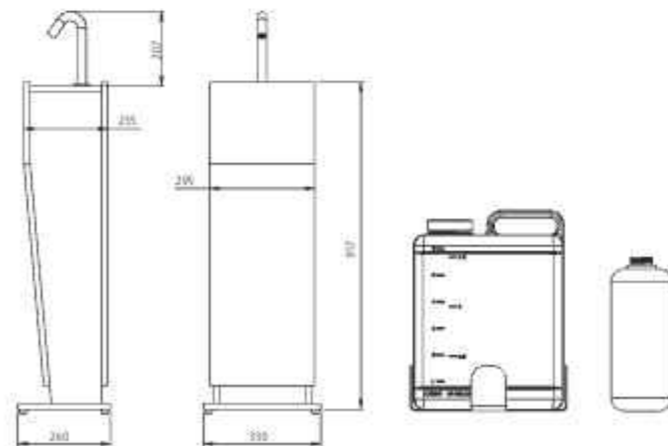

## TOUCH FREE HAND SANITIZER PILLAR

Touch-free electronic hand sanitizer stand for deck-mounted installations with dripless automatic shutoff. Suitable for supermarkets, banks, lobbies and any high traffic public areas.

### Features:

- 100% heavy-duty one piece brass body
- Delivers non-proprietary hand sanitizer
- Chrome plated brass body dispenser
- Power Supply: Battery box for six (6) D batteries or 12V transformer
- Peristaltic pump
- Adjustable settings



# 1L

### TOUCH FREE HAND SANITIZER STAND 1L

- **281100CSB CSABA TOUCH FREE HAND SANITIZER PILLAR 1L**  
Battery box for six (6) D batteries
- **281100CSE CSABA TOUCH FREE HAND SANITIZER PILLAR 1L**  
12V Transformer

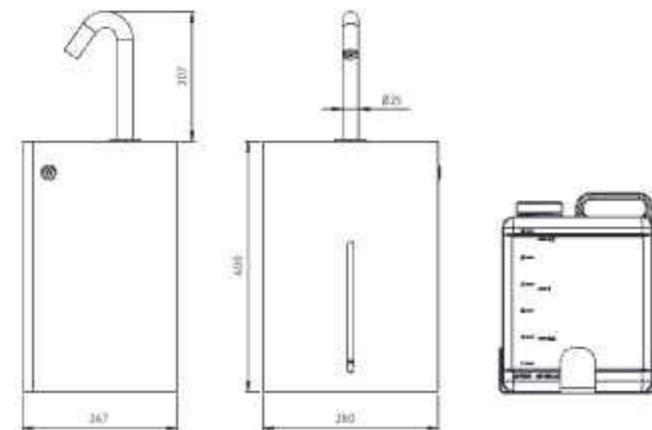
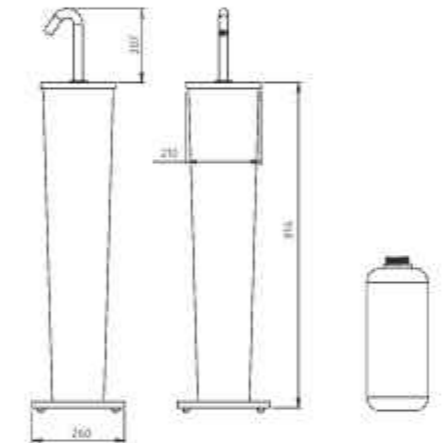



# BEHIND THE MIRROR & HAND DRYERS



SWAR  
SOAP WATER AIR  
REVOLUTION 83-87



BEHIND THE MIRROR  
PAPER HOLDER 91



RECESSED MOUNTING  
DUO 88



BEHIND MIRROR  
SOAP DISPENSER 92



SWA HI-SPEED  
MODULE 89-90



EVER HAND DRYER 93



BEHIND MIRROR  
FAUCET 91



TUBULAR HAND DRYER 94

Tailor your mirror cabinet by choosing its interior components.

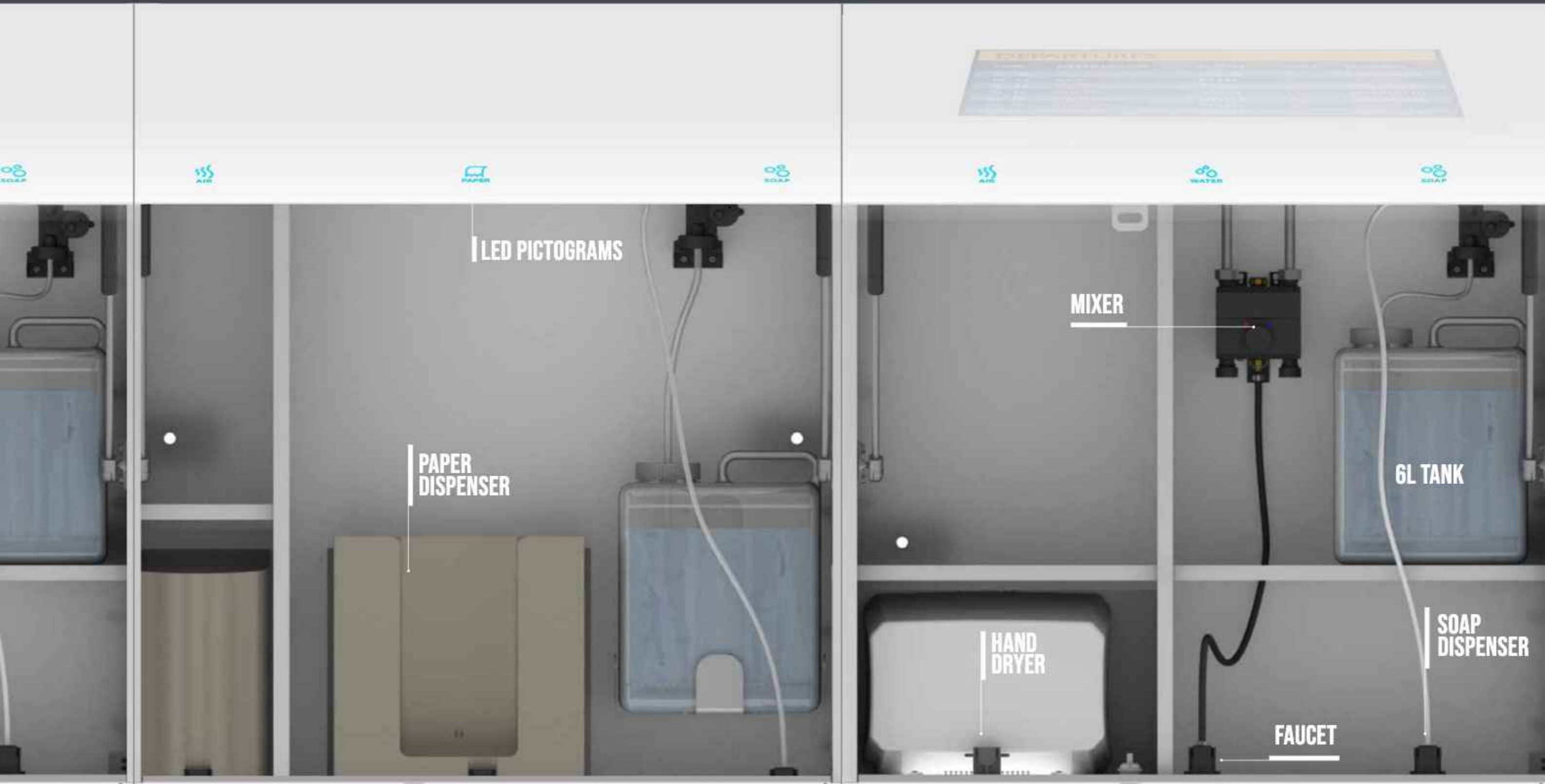

#### SOAP

- Soap Dispenser
- Foam Dispenser
- 6-liter Tank
- 2-liter Tank
- No Soap Dispenser

#### RINSE

- Cold Water
- Premixed Water
- Cartridge Mixer
- Thermostatic Mixer

#### DRY

- Touch-Free Hand Dryer
- Paper Dispenser

Once you've made your selections for the interior products, you can pick from the available cabinet dimensions:

- Width
- Length
- Depth (for Paper Dispenser):

COMPLEMENTARY PRODUCTS: Bridge Cabinets



# SWAR TV

Best of BDNY Award Winner

### Complete sanitary cabinet with a lockable mirror and 23.5" TV

Includes high speed hand dryer, mixing valve, touch-free faucet, touch-free soap dispenser and LED pictograms for intuitive user guidance and decoration.

The monitor is part of the mirror. When a user comes close to the monitor it becomes a mirror. The monitor can receive input via a cable connection or WIFI.

- 280461 SWAR TV, 12V transformer

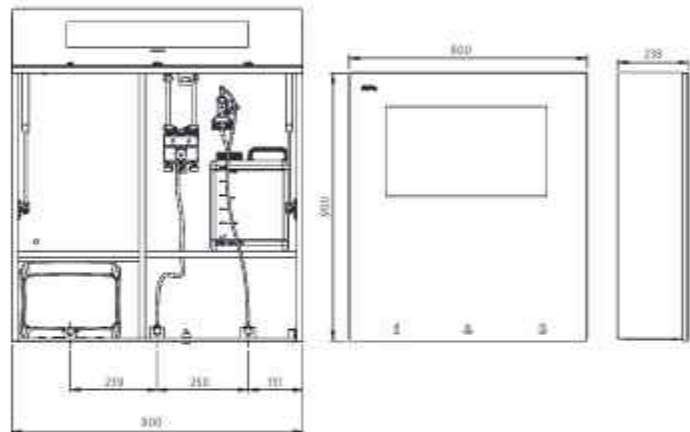

# SWAR CITY

### Sanitary cabinet with a lockable mirror for budget projects

Includes high speed hand dryer, touch-free faucet, touch-free soap dispenser and LED pictograms for intuitive user guidance and decoration in one color.

Delivered with remote control to adjust soap dosage and customize the faucet settings.

- Eliminates messy, slippery floors and hand drying queues
- Reduces the amount of labor for commercial facilities maintenance
- Electrical connection supplied according to your region / needs

- 280455 SWAR CITY

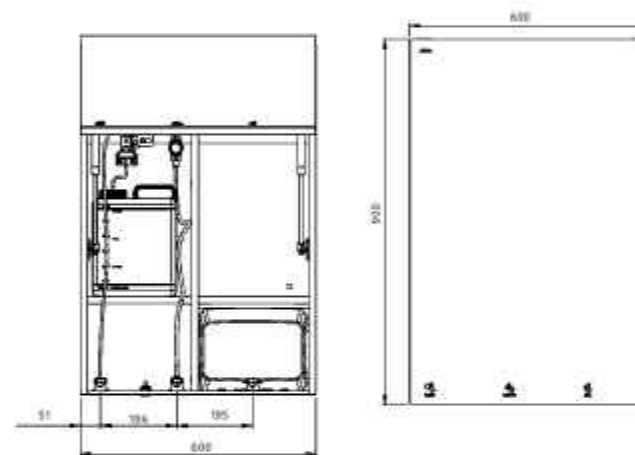

# SWAR

## Complete sanitary cabinet with a lockable mirror

Includes high speed hand dryer, mixing valve, touch-free faucet, touch-free soap dispenser and LED pictograms for intuitive user guidance and decoration.

Delivered with remote controls to adjust soap dosage, select light color or sequence and customize the faucet settings.

- Eliminates messy, slippery floors and hand drying queues
- Reduces the amount of labor for commercial facilities maintenance
- Electrical connection supplied according to your region/needs

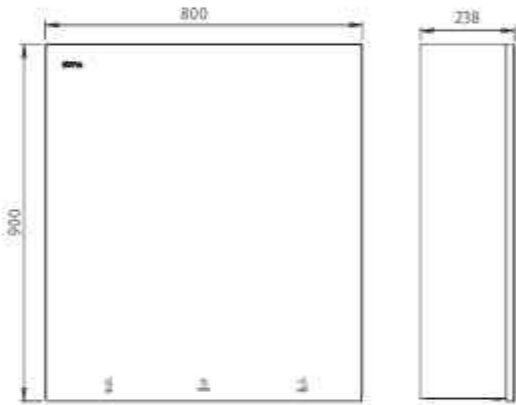

- 280460-US SWAR US, 12V transformer
- 280460-UK SWAR UK, 12V transformer
- 280460-EU SWAR EU, 12V transformer
- 280460-HW SWAR HARDWIRED, 12V transformer

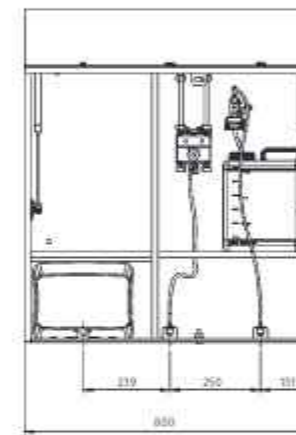

- 280460 SWAR 12V transformer  
See page 87

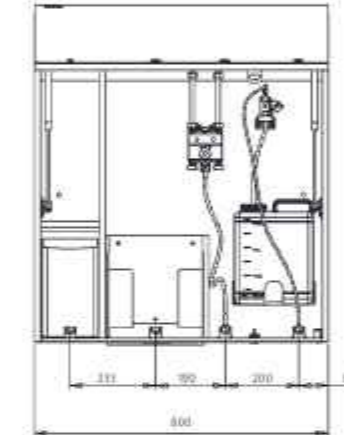

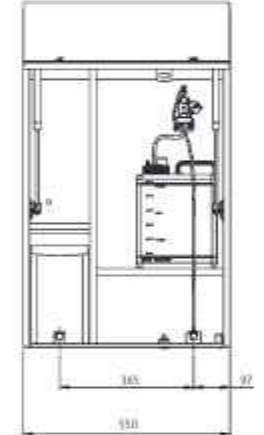

- 280470 SWAR P 12V transformer  
Includes: hand dryer, mixing valve, touch-free faucet, soap dispenser and paper towel dispenser



- 280476 SA MODULE 12V transformer  
Includes: touch-free soap dispenser and hand dryer



	Stern's SWAR TV	Stern's original SWAR	Stern's SWAR City
			
Water Temperature	Integrated mixer to adjust the temperature	One inlet with optional thermostatic mixing valve.	One inlet with optional thermostatic mixing valve.
Length	800 mm * 600 mm and other bespoke sizes available upon request. Terminating cabinet available.	800 mm * Bespoke sizes available upon request	600 mm * Bespoke sizes available upon request
Material	Available in 6 colors: Snow White, Ivory White, Back, Gray, Graphite and Oak	Available in 6 colors: Snow White, Ivory White, Back, Gray, Graphite and Oak	Available in White or Black
Mirror & indicative icons	4 mm thick glass mirror with full MDF inside. Intuitive illuminated LED pictograms for intuitive user's guide and decoration. The color of the light or a sequence of colors can be selected using the provided remote control.	4 mm thick glass mirror with full MDF inside. Intuitive illuminated LED pictograms for intuitive user's guide and decoration. White LED illuminated icons.	4 mm thick glass mirror with full MDF inside. Intuitive illuminated LED pictograms for intuitive user's guide and decoration. White LED illuminated icons.
Soap tank capacity	6 litres tank automatic soap dispenser. Soap can be primed with the provided remote control or with the individual button at the pump. Multifeed option available. 1 tank can be used to serve up to 6 SWAR cabinets.	6 litres tank automatic soap dispenser. Soap can be primed with the provided remote control or with the individual button at the pump. Multifeed option available. 1 tank can be used to serve up to 6 SWAR cabinets.	6 litres tank automatic soap dispenser. Soap can be primed with the provided remote control or with the individual button at the pump. Multifeed option available. 1 tank can be used to serve up to 6 SWAR cabinets.
Soap viscosity	Since Stern's pump is peristaltic, it works with a big range of viscosities from 100 to up to 3,800 cP.	Since Stern's pump is peristaltic, it works with a big range of viscosities from 100 to up to 3,800 cP.	Since Stern's pump is peristaltic, it works with a big range of viscosities from 100 to up to 3,800 cP.
Special features included	Incorporated TV monitor allowing the display of user information, advertisements, or entertainment.	N-A	N-A
Optional features and accessories	Soap level indicator to be displayed by the soap icon.	Soap level indicator to be displayed by the soap icon.	Thermostatic mixing valve



**NEW!**

## RECESSED MOUNTING DUO

Touchless soap dispenser and faucet for recessed mounting behind the mirror or panel

Complete system including TMV to limit the hot water temperature and Soap and Water remote control.

- 280500 RECESSED MOUNTING DUO

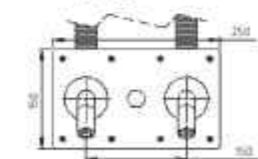
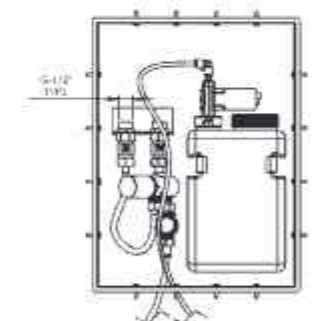

with Extreme CS duo

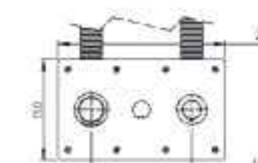

with Tubular duo

# SWA HI-SPEED MODULE

Complete system including high speed hand dryer, thermostatic mixing valve, touch-free faucet, liquid soap dispenser and optional lamp soap level indicator

- Ready to be integrated behind the mirror for a clear, minimalistic design
- Eliminates messy, slippery floors and hand drying queues
- Reduces the amount of labor for commercial facilities maintenance
- Easy installation with a stainless steel frame to be fixed to the wall
- Ideal touch-free soap-water-air cycle
- Helps prevent cross contamination
- Reduces water and soap consumption
- To be used with non-proprietary soap
- Drying time: less than 15 seconds

### TAILORED TO YOUR NEEDS:

The SWA Module's complete version includes a touch-free soap or foam dispenser, faucet, thermostatic mixing valve and hand dryer. Each component can be delivered individually with any combination you prefer.



\* System including paper dispenser instead of hand dryer also available upon request



Complete system including high speed hand dryer (1), thermostatic mixing valve (2), touch-free faucet (3) liquid soap dispenser (4) and optional lamp soap level indicator (5)

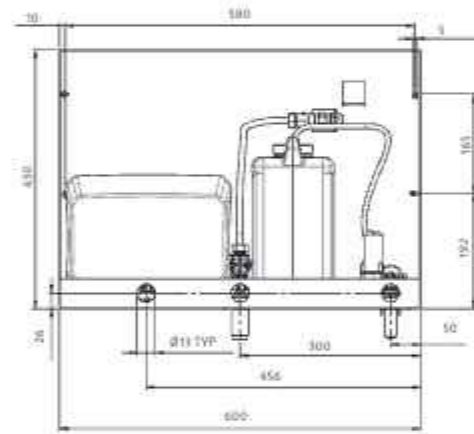

• 280410 12V transformer



Modular system including high speed hand dryer (1), touch-free faucet (2) and liquid soap dispenser (3) and optional lamp soap level indicator (5)

Modular system including high speed hand dryer (1) and liquid soap dispenser (4) and optional lamp soap level indicator (5)

Modular system including touch-free faucet (3) and liquid soap dispenser (4) and optional lamp soap level indicator (5)

Modular system including thermostatic mixing valve (2), touch-free faucet (3) and liquid soap dispenser (4) and optional lamp soap level indicator (5)



## BTM FAUCET

Electronic wall-mounted faucet for integration behind the mirror

- Drastically reduces water consumption
- No physical contact. Helps to protect users against cross contamination
- Sensor settings adjustable by remote control
- Easy installation behind the mirror
- Matching IR operated soap dispenser



- 280310 **BTM B**, Battery box for 6 x 1.5V AA batteries
- 280300 **BTM E**, 9V transformer

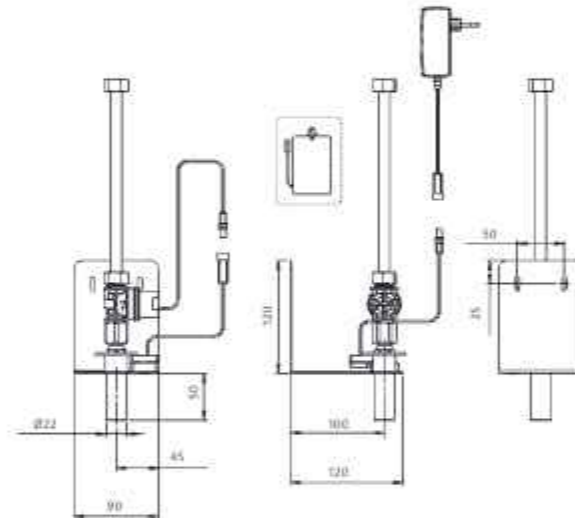

## BTM PAPER TOWEL HOLDER

- 316 Stainless steel
- For integration behind the mirror as part of the SWA electronic wall mounted system
- Easy installation
- Saves space and functional solution that accommodates standard paper towels from your favorite brands (paper towels not included)

- 03300148 **PAPER TOWEL HOLDER**

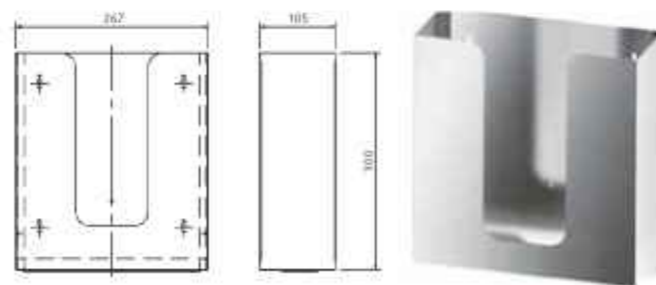

## BTM SOAP DISPENSER

Touch-free electronic soap dispenser for integration behind the mirror

- Drastically reduces soap consumption
- No physical contact. Helps to protect users against cross contamination
- Peristaltic pump. The soap is driven inside the soap tube without contact with the pump, preventing contamination and back flow
- Accurate soap dosage
- To be used with non-proprietary soap for maximum savings
- Easy to install and refill
- Matching IR operated faucet



### 1L

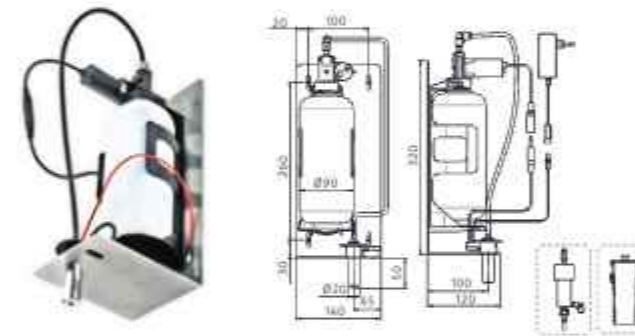

#### BEHIND MIRROR SD

Delivers liquid soap/foam

- 280210 **BEHIND MIRROR SD B**, Battery box for six (6) D batteries
- 280200 **BEHIND MIRROR SD E**, 12V Transformer
- 280250 **BTM FOAM E**, 12V Transformer

### 6L

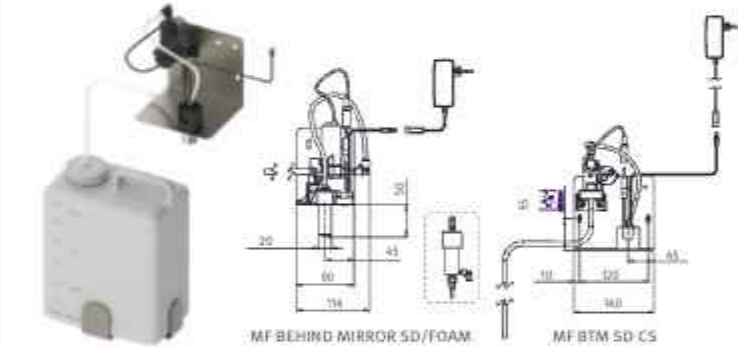

#### MF BEHIND MIRROR SD

Soap dispenser to be used with Stern's Multifeed kits for multiple refill. Delivers liquid soap/foam.

- 07292223 **MF BEHIND MIRROR SD**, 12V Transformer
- 07292270 **MF BEHIND MIRROR FOAM**, 12V Transformer
- 07292278 **MF BTM SD CS**, 12V Transformer

#### MULTIFEED KIT

Allows multiple soap dispenser refill (up to 6 dispensers) with a single 1.6 US Gallons (6 liters) tank.

- 07220096 **MULTIFEED KIT**

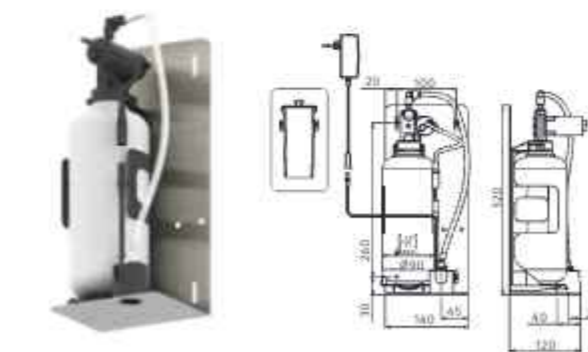
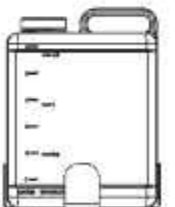

#### BTM SD CS

Concealed spout  
Delivers liquid soap/foam

- 280225 **BTM SD CS B**, Battery box for six (6) D batteries
- 280220 **BTM SD CS E**, 12V Transformer



## EVER HD

### Electronic deck-mounted hand dryer operated by IR sensor

Touch-free electronic hand dryer for deck-mounted installations.

Powered by 110V-120/220V-240VAC.

Hand dryer will automatically shut off after being used for more than 60 seconds. Sensor settings can be customized by remote control.

Includes motor and heater thermal protection in case of overheating.

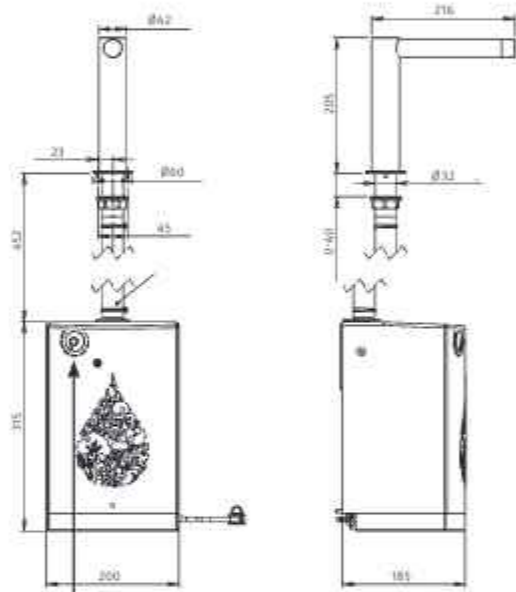

Airflow intensity adjustment button

### EVER HD

- 230510 EVER HD, 110V-120/220V-240VAC
- 230520 EVER HD AISI316, 110V-120/220V-240VAC



### Advantages:

- HEPA filter for added hygienic properties
- Full brass body or stainless steel 316 material
- Variety of colors and special finishes available
- Matching touch-free faucet and soap dispenser
- Long lasting, durable and vandal resistant
- Air flow intensity adjustable by external button
- Adjustability with remote control: security time, detection range, delay out
- On/Off function to perform cleaning



## TUBULAR HD

### Electronic wall-mounted hand dryer operated by IR sensor

Touch-free electronic hand dryer for wall-mounted installations.

Powered by 110V-120/220V-240VAC.

Hand dryer will automatically shut off after being used for more than 60 seconds. Sensor settings can be customized by remote control.

Includes motor and heater thermal protection in case of overheating.

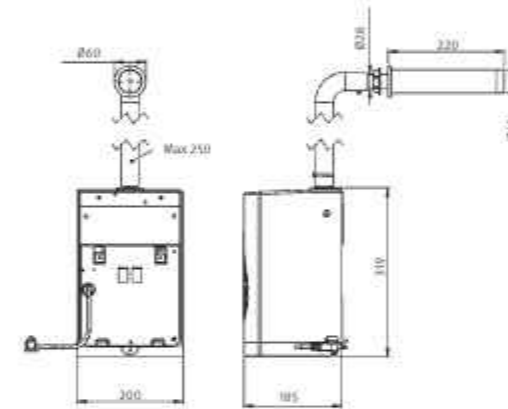

### TUBULAR HD

Concealed installation in dry walls  
110V-120/220V-240VAC

- 350030 TUBULAR HD
- 350040 TUBULAR HD AISI316



### TUBULAR DP HD

Concealed installation in dry walls as well as concrete and brick walls  
110V-120/220V-240VAC

- 350020 TUBULAR DP HD
- 350010 TUBULAR DP HD AISI316

### Advantages:

- HEPA filter for added hygienic properties
- Full brass body or stainless steel 316 material
- Variety of colors and special finishes available
- Matching touch-free faucet and soap dispenser
- Long lasting, durable and vandal resistant
- Air flow intensity adjustable by external button
- Adjustability with remote control: security time, detection range, delay out
- On/Off function to perform cleaning



# TOILETS & URINALS

	NOBLE 2032	115		PROX & WAVE SENSOR KIT FOR TOILET	125
	NOBLE 3032	116		ELECTROMAGNETIC CISTERN SYSTEM	126
	NARA 2032 NARA 2022	117 - 119		JUPITER 2040	127
	VENUS COMFORT 2032	120		NARA 2030	128
	VENUS COMFORT 2032 DF	121		JUPITER 1032	129
	PERFECT TIME 2032	121		JUPITER 1011	129
	VENUS 3002	122		FREE	130
	APS KIT FOR TOILETS WITH DISTANT CONTROL	123		JUPITER 3002	131
	PROX, WAVE & TOUCH SOLUTIONS FOR TOILET	124		PROX FOR URINALS	132

## NOBLE 2032 SERIES

### Concealed electronic flush valve for toilet, operated by an IR sensor

Features a dual flush IR system. Includes models with a Piezo override flush activator switch giving the user the possibility of alternative manual touch activation. Flushing duration and other settings are adjustable by remote control.

**Dual flush:** Water will flush after the user moves away from the toilet. If the user spends less than one minute in front of the sensor a half flush (3 liters) will take place. For more than one minute in front of the sensor a full flush (4.5 liters) will take place.

**Hygiene Flush:** To maximize hygiene, this product is equipped with a 24 hour duty flush. The flush takes place after 24 hours of non-use. Prevents the trap seal from drying out, possible freezing of pipes and potential bacteria in standing water. This function can be disabled using the remote control.

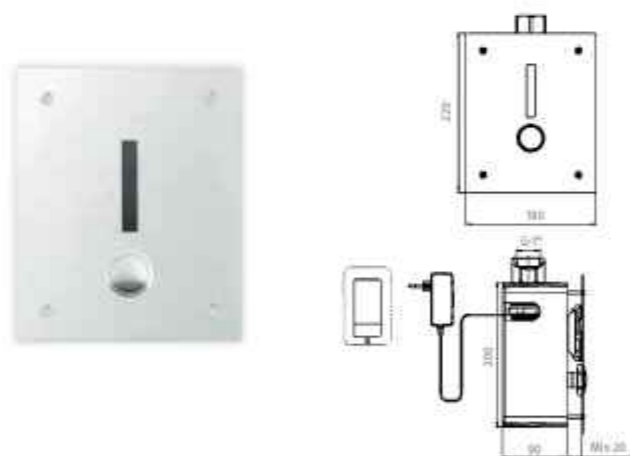

### NOBLE 2032

Dual flush operation  
With a mechanical override flush button  
Iron frame available

- 460640 NOBLE 2032, 9V battery
- 460600 NOBLE 2032 E, 9V Transformer

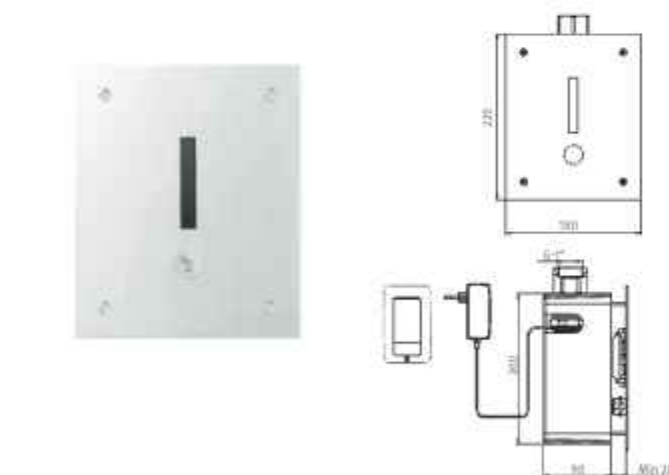

### NOBLE 2032 P

Dual flush operation  
With a touch flush activator button

- 460630 NOBLE 2032 P, 9V battery
- 460610 NOBLE 2032 PE, 9V Transformer

## NOBLE 3032 SERIES

### Concealed electronic flush valve for toilet, operated by an IR sensor

Features a dual flush IR system. Includes models with a Piezo override flush activator switch giving the user the possibility of alternative manual touch activation. Flushing duration and other settings are adjustable by remote control. Stainless steel AISI316 panel.

**Dual flush:** Water will flush after the user moves away from the toilet. If the user spends less than one minute in front of the sensor a half flush (3 liters) will take place. For more than one minute in front of the sensor a full flush (6 liters) will take place.

**Hygiene Flush:** To maximize hygiene, this product is equipped with a 24 hour duty flush. The flush takes place after 24 hours of non-use. Prevents the trap seal from drying out, possible freezing of pipes and potential bacteria in standing water. This function can be disabled using the remote control.

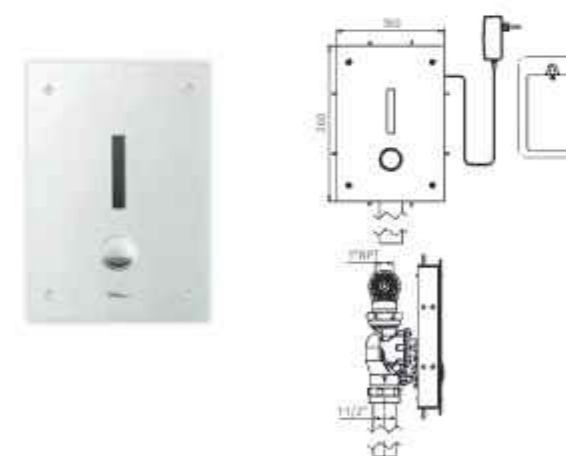

### NOBLE 3032

Dual flush  
A half flush (3 liters) will take place. For more than one minute, a full flush (6 liters) will take place  
Manual override push button anti-block feature  
Iron frame available

- 460700 NOBLE 3032, 6 x 1.5V batteries
- 460710 NOBLE 3032 E, 9V Transformer

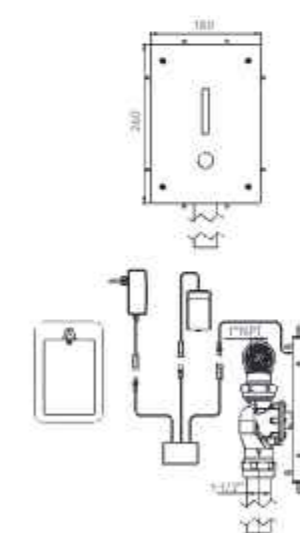

### NOBLE 3032 P

Dual flush  
A half flush (3 liters) will take place. For more than one minute, a full flush (6 liters) will take place  
Piezo override push button anti-block feature  
Iron frame available

- 460720 NOBLE 3032 P, 6 x 1.5V batteries
- 460730 NOBLE 3032 PE, 9V Transformer



## NARA 2032 SERIES

**Concealed electronic flush valve for toilet operated by IR sensor**  
**Features a dual flush IR system**

Includes models with a Piezo override flush activator switch giving the user the possibility of alternative manual touch activation. Flushing duration and other settings are adjustable by remote control.

**Dual flush:** Water will flush after the user moves away from the toilet. If the user spends less than one minute in front of the sensor, a half flush (3 liters) will take place. For more than one minute, a full flush (6 liters) will take place.

**Hygiene Flush:** To maximize hygiene, this product is equipped with a 24 hour duty flush. The flush takes place after 24 hours of non-use. Prevents the trap seal from drying out, possible freezing of pipes and potential bacteria in standing water. This function can be disabled using the remote control.



## NARA 2022 SERIES

**Concealed electronic flush valve for toilet operated by IR sensor**  
**Features a dual flush IR system**

Includes models with a Piezo override flush activator switch giving the user the possibility of alternative manual touch activation. Flushing duration and other settings are adjustable by remote control.

**Dual flush:** Water will flush after the user moves away from the toilet. If the user spends less than one minute in front of the sensor, a half flush (3 liters) will take place. For more than one minute, a full flush (6 liters) will take place.

**Hygiene Flush:** To maximize hygiene, this product is equipped with a 24 hour duty flush. The flush takes place after 24 hours of non-use. Prevents the trap seal from drying out, possible freezing of pipes and potential bacteria in standing water. This function can be disabled using the remote control.

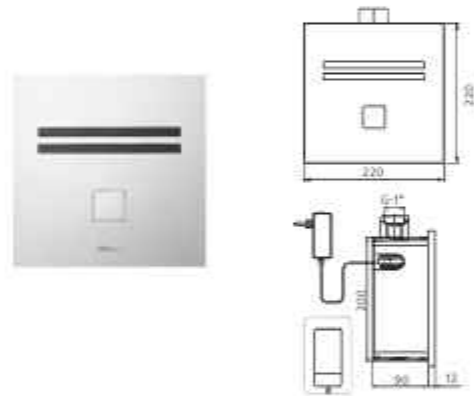

### NARA 2032

Dual flush

A half flush (3 liters) will take place. For more than one minute, a full flush (6liters) will take place.

Features a mechanical override flush activator button  
 Iron frame available. See also page 137

- 160310 NARA 2032 , 9V Battery
- 160410 NARA 2032 E, 9V Transformer

### NARA ECO 2032

Dual flush

A half flush (3 liters) will take place. For more than one minute, a Leed full flush (4.5 liters) will take place.

Features a mechanical override flush activator button  
 Iron frame available. See also page 137

- 160320 NARA ECO 2032 , 9V battery
- 160330 NARA ECO 2032 E, 9V Transformer

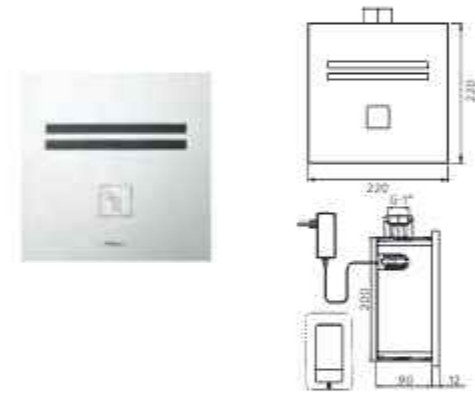

### NARA 2032 P

Dual flush

A half flush (3 liters) will take place. For more than one minute, a full flush (6liters) will take place.

Features a touch flush activator button  
 Iron frame available. See also page 137

- 160610 NARA 2032 P, 9V Battery
- 160510 NARA 2032 PE, 9V Transformer

### NARA ECO 2032 P

Dual flush

A half flush (3 liters) will take place. For more than one minute, a Leed full flush (4.5 liters) will take place.

Features a touch flush activator button  
 Iron frame available. See also page 137

- 160340 NARA ECO 2032 PE, 9V Transformer

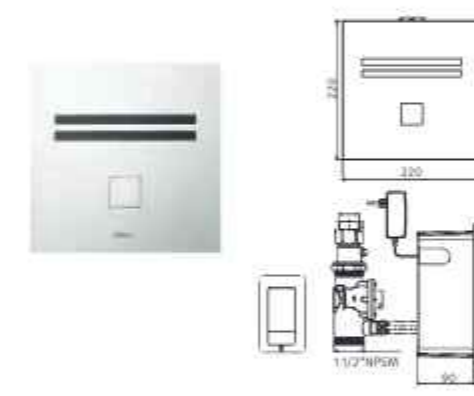

### NARA 2022

Dual flush

A half flush (3 liters) will take place. For more than one minute, a full flush (6liters) will take place.

Features an hydraulic override flush activator button

- 160750 NARA 2022, 9V Battery
- 160700 NARA 2022 E, 9V Transformer

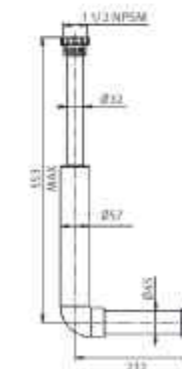

### ACCESSORIES

- 07291037 SET OF PIPES  
 Set of pipes for in wall installation



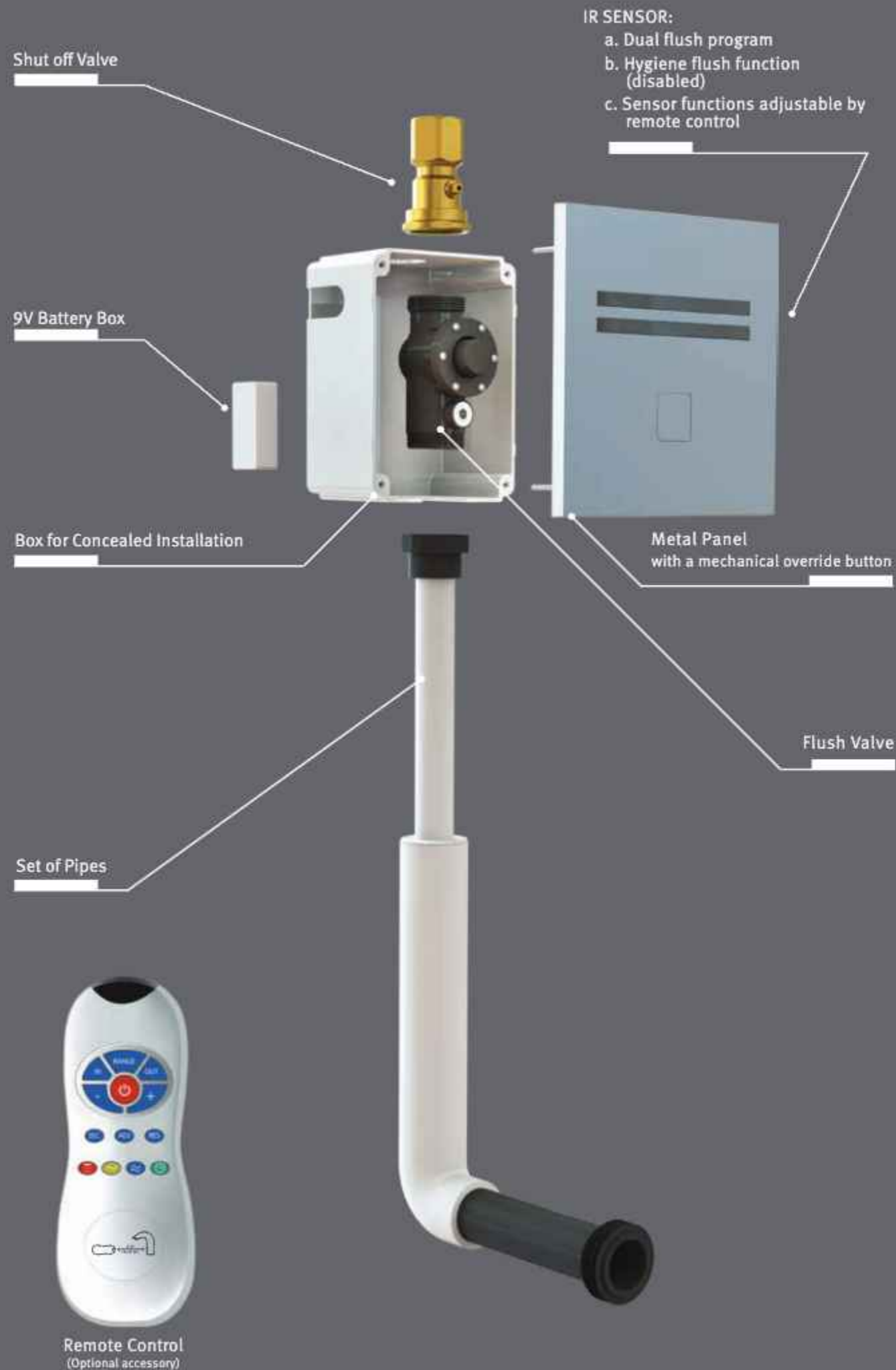

## VENUS COMFORT 2032 SERIES

**Concealed electronic flush valve for toilet operated by IR sensor**  
Dual flush IR system upon request. Includes models with a Piezo override flush activator switch, giving the user the possibility of alternative flushing with an easy touch activation. Flushing duration and other settings are adjustable by remote control.

**Hygiene Flush:** To maximize hygiene, this product is equipped with a 24 hour duty flush. The flush takes place after 24 hours of non-use. Prevents the trap seal from drying out, possible freezing of pipes and potential bacteria in standing water. This function can be disabled using the remote control.



### VENUS COMFORT 2032

Optional dual flush  
Features a manual override flush activator button  
Iron frame available. See also page 138

- 410562 VENUS COMFORT 2032, 9V battery
- 410541 VENUS COMFORT 2032 E, 9V Transformer

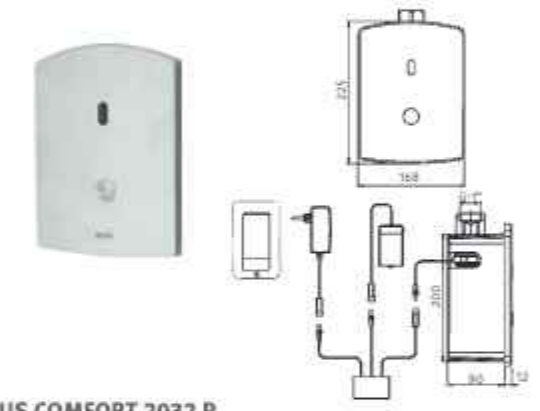

### VENUS COMFORT 2032 P

Optional dual flush  
Features a piezo override flush activator button  
Iron frame available. See also page 138

- 410576 VENUS COMFORT 2032 P, 9V battery
- 410546 VENUS COMFORT 2032 PE, 9V Transformer

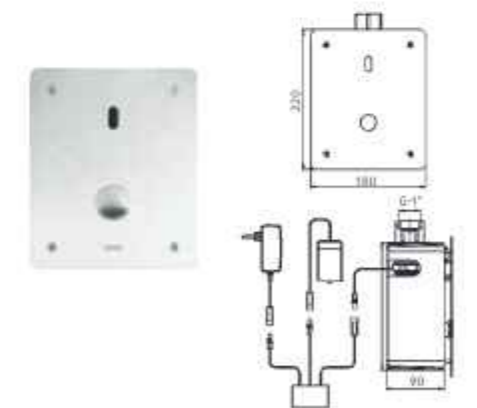

### VENUS XS 2032

Features a manual override flush activator button  
Optional dual flush

- 410601 VENUS XS 2032E, 9V Transformer

## VENUS COMFORT 2032 DF

**Concealed electronic self closing flush valve for toilet operated by touch**

Features two Piezo switches integrated in the panel for dual flush operation. Flushing duration can be changed on site according to the specific site requirements.

**Hygiene Flush:** To maximize hygiene, this product is equipped with a 24 hour duty flush. The flush takes place after 24 hours of non-use. Prevents the trap seal from drying out, possible freezing of pipes and potential bacteria in standing water. This function can be disabled using the remote control.

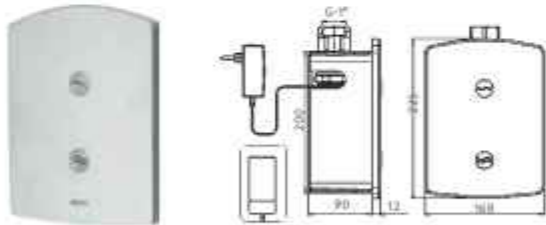

### VENUS COMFORT 2032 DF

Dual Flush

Iron frame available

See also page 138

Full (6) six liter flush operation occurs, when the user touches the button indicated with two waves. A reduced (3) three liter flush operation is activated when the user touches the button indicated with one wave.

- 410446 VENUS COMFORT 2032 DF, 9V Battery
- 410447 VENUS COMFORT 2032 DFE, 9V Transformer

## PERFECT TIME 2032

**Concealed electronic self closing flush valve for toilet operated by touch**

Features a Piezo switch integrated in the panel. Flushing duration can be changed on site according to the specific site requirements.

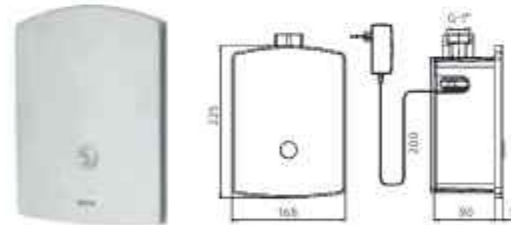

### PERFECT TIME 2032

Iron frame available

See also page 138

- 410761 PERFECT TIME 2032 E, 9V Transformer

## VENUS 3002 SERIES

**Exposed electronic flush valve for toilet operated by IR sensor**

Includes a manual override flush activator button, integral flow regulator, in line filter, high pressure vacuum breaker and adjustable tail piece. Flushing duration and other settings are adjustable by remote control.

**Hygiene Flush:** To maximize hygiene, this product is equipped with a 24 hour duty flush. The flush takes place after 24 hours of non-use. Prevents the trap seal from drying out, possible freezing of pipes and potential bacteria in standing water. This function can be disabled using the remote control.

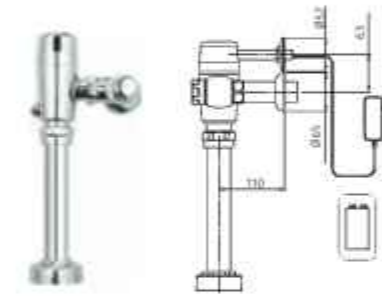

### VENUS 1.28 GPF

Side inlet

Specially designed for the needs of the North American market

- 420242 VENUS 1.28 GPF, Internal 9V battery
- 420232 VENUS E 1.28 GPF, 9V Transformer

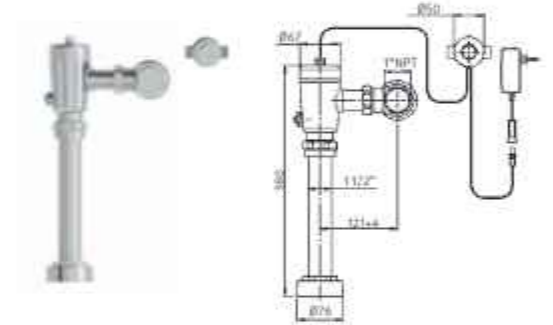

### VENUS 3003R PE

Designated for high security locations

Operated by remote activation with piezo button located in the inmate's cell, while the flush valve body is concealed in the service area. Each activation gives a pre-set run cycle

Allows activation of the toilet once the user touches the designated area in the Piezo button

- 420280 VENUS 3003R PE, 9V Transformer

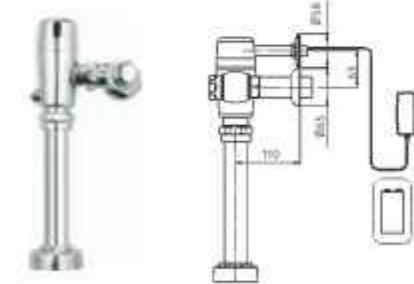

### VENUS 3002 R

Side inlet

Manual override flush activator button

Allows automatic activation when the users have left the toilet

- 420241 VENUS 3002 R, Internal 9V battery
- 420265 VENUS 3002 RE, 9V Transformer

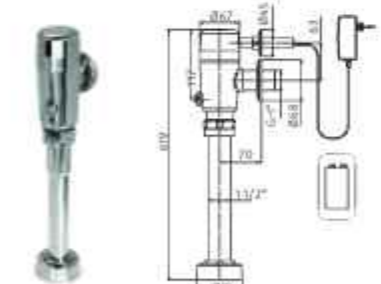

### VENUS 3002

Rear inlet

Features a mechanical override push button to enable manual operation. Dual flush version available

- 420255 VENUS 3002, Internal 9V battery
- 420231 VENUS 3002 E, 9V Transformer



## PROX & WAVE SENSOR KIT FOR TOILET WITH PRIMARY FLUSH

This kit is designed to operate a two volumes flush valve. The sensor detects the user at a given distance, and operates an automatic flush using the sensor's prox function once the user has left the toilet. Depending on time and distance, the systems delivers 3 liters to evacuate liquids and 6 liters to evacuate solids. To maximize hygiene, the system allows the user upon arriving to the toilet to operate a primary cleaning flush using the sensor's wave function.

**Hygiene Flush:** To maximize hygiene, this product is equipped with a 24 hour duty flush. The flush takes place after 24 hours of non-use. Prevents the trap seal from drying out, possible freezing of pipes and potential bacteria in standing water. This function can be disabled using the remote control.



### PROX & WAVE SENSOR KIT FOR TOILET

Suitable for duct concealed installations (plaster walls).

#### Primary cleaning flush

Allows the user to operate a cleaning flush before using the system. The 3 liters flush takes places when the user presents his hand at a short distance at the front of the sensor.

#### Dual Flush

The system will operate a half flush (3 liters) or a full flush (6 liters) based on a time and distance equation.

- 620100 -Prox/Wave PROX & WAVE SENSOR KIT FOR TOILET, 9V Battery / 9V Transformer (not included)

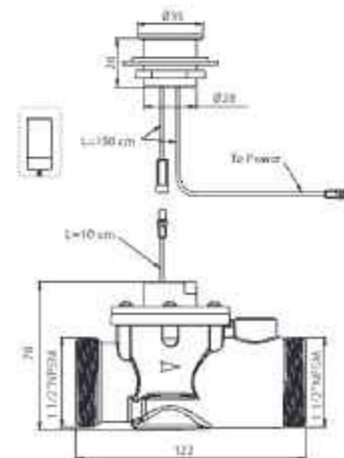

## ELECTROMAGNETIC CISTERN SYSTEM

### Concealed electronic flushing system for cistern activated by an infrared wave sensor

Options for a single or dual flush activations. Includes an integral overflow pipe (warning pipe) to prevent flooding, and two integrated filters.

Pre-flush optional upon request. Hygiene flush is included. Flushing duration and other settings are adjustable by remote control. 72 hours hygiene flush after every activation.

**Hygiene Flush:** To maximize hygiene, this product is equipped with a 24 hour duty flush. The flush takes place after 24 hours of non-use. Prevents the trap seal from drying out, possible freezing of pipes and potential bacteria in standing water. This function can be disabled using the remote control.

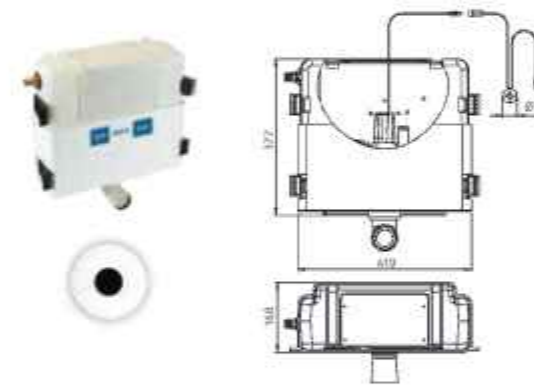

### ELECTROMAGNETIC SF CISTERN

#### Single flush

Allows flushing of the toilet once the users place their hands within the sensor range. Available in a variety of special finishes.

- 620620 ELECTROMAGNETIC SF CISTERN, 12V 2.5 Amp IP68 Transformer

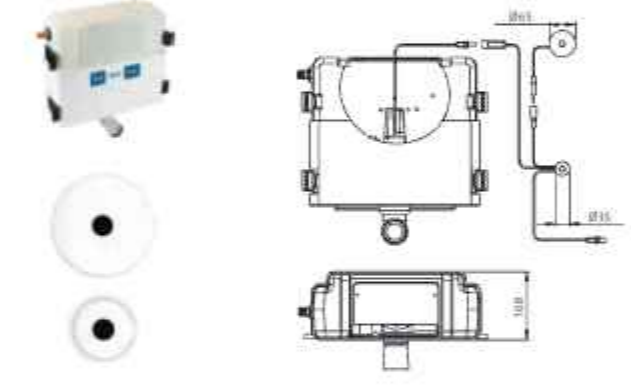

### ELECTROMAGNETIC DF CISTERN

#### Dual flush

Allows flushing of the toilet once the users place their hands within sensor range. Operating the small sensor will activate a half flush (3 liters) and operating the large sensor will activate a full flush (6 liters).

- 620630 ELECTROMAGNETIC DF CISTERN, 12V 2.5 Amp IP68 Transformer

ACCESSORIES			
	1. DF EL. CISTERN VALVE W/OVERRIDE	07140067	
	2. WAVE ON/OFF FOR CISTERN	07224101	
	3. ADJUSTMENT ARM FOR C57(VERB)	07120348	
	4. IP68 ENCAP.SWITCH 13.5V/2.5A TRANSFORMER EU-M	06522142	

## JUPITER 2040 SERIES

**Concealed electronic flush valve for urinal operated by IR sensor**  
Flushing duration and other settings are adjustable by remote control.  
Stainless steel AISI316 panel.



**Hygiene Flush:** To maximize hygiene, this product is equipped with a 24 hour duty flush. The flush takes place after 24 hours of non-use. Prevents the trap seal from drying out, possible freezing of pipes and potential bacteria in standing water. This function can be disabled using the remote control.

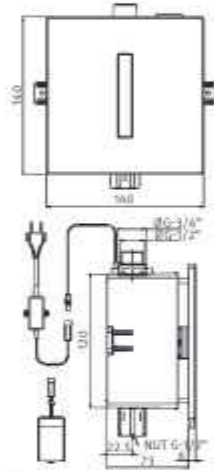

### JUPITER 2040

Iron frame available. See also page 139

- 125900 JUPITER 2040 , Internal 9V battery
- 125901 JUPITER 2040 E, 9V Transformer

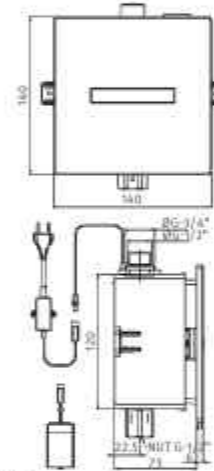

### JUPITER 2040 H

Iron frame available. See also page 139

- 125910 JUPITER 2040 H , Internal 9V battery
- 125911 JUPITER 2040 HE, 9V Transformer



## NARA 2030 SERIES

**Concealed electronic flush valve for urinal operated by IR sensor**  
Flushing duration and other settings are adjustable by remote control.



**Hygiene Flush:** To maximize hygiene, this product is equipped with a 24 hour duty flush. The flush takes place after 24 hours of non-use. Prevents the trap seal from drying out, possible freezing of pipes and potential bacteria in standing water. This function can be disabled using the remote control.

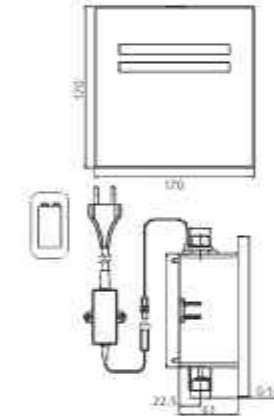
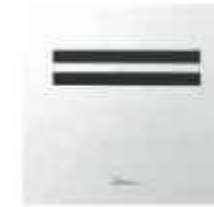

### NARA 2030

Iron frame available. See also page 139

- 170200 NARA 2030 , Internal 9V battery
- 170100 NARA 2030 E, 9V Transformer





## JUPITER 3002 SERIES

### Exposed electronic flush valve for urinal operated by IR sensor

Includes a manual override flush activator button, integral flow regulator, in line filter, high pressure vacuum breaker and adjustable tail piece. Flushing duration and other settings are adjustable by remote control.

**Hygiene Flush:** To maximize hygiene, this product is equipped with a 24 hour duty flush. The flush takes place after 24 hours of non-use. Prevents the trap seal from drying out, possible freezing of pipes and potential bacteria in standing water. This function can be disabled using the remote control.



## PROX SOLUTIONS

### Electronic flush valve kit for urinal

Flushing duration and other settings are adjustable by remote control. Available with detachable body.

**Hygiene Flush:** To maximize hygiene, this product is equipped with a 24 hour duty flush. The flush takes place after 24 hours of non-use. Prevents the trap seal from drying out, possible freezing of pipes and potential bacteria in standing water. This function can be disabled using the remote control.



### Prox Sensors with Special Finishes

Touch free prox sensor operation now available in a wide variety of special finishes to complete the interior design of your commercial restroom.

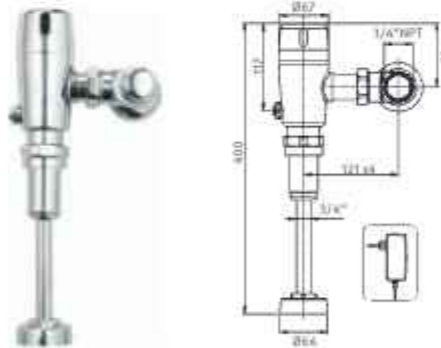

### JUPITER M 0.5 GPF

Side inlet  
Manual override flush activator button  
Specially designed for the needs of the North American market

- 140112 JUPITER M 0.5 GPF, Internal 9V battery
- 140516 JUPITER ME 0.5 GPF, 9V Transformer

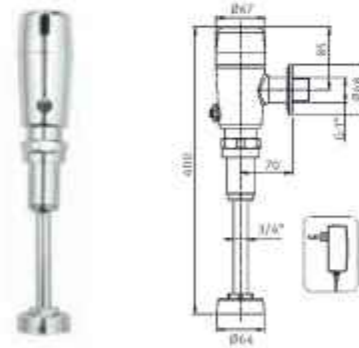

### JUPITER 3002 M

Rear inlet  
Manual override flush activator button

- 140215 JUPITER 3002 M, Internal 9V battery
- 140315 JUPITER 3002 EM, 9V Transformer

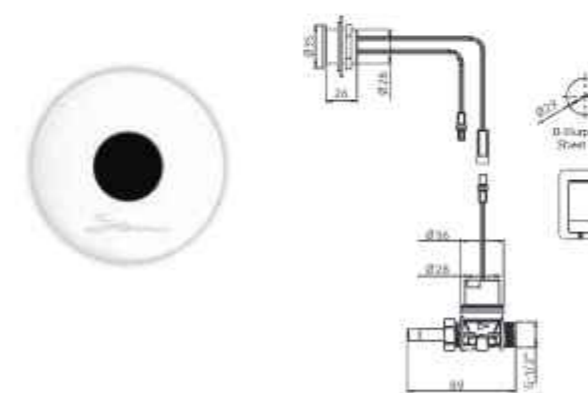

### PROX KIT FOR URINAL

Suitable for duct concealed installations (plaster walls)

- 620700 PROX KIT FOR URINAL, 9V Battery / 9V Transformer

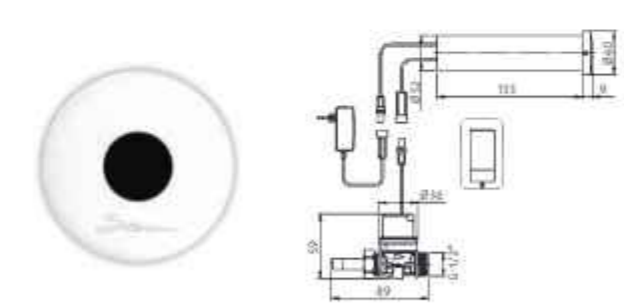

### PROX FRONT FIXATION KIT FOR URINALS



Suitable for concrete walls installation

- 620750 PROX FRONT FIXATION KIT FOR URINALS, 9V Battery / 9V Transformer





# IRON FRAME SETS

	SOAP, WATER & AIR FRAME SETS	135 - 136
	W.C. FRAME SETS	137 - 138
	URINALS FRAME SETS	139
	ARTIS H CISTERN FRAME SET	140

## SOAP, WATER & AIR FRAME SETS

### Iron mounting frame set

Touch-free soap dispenser, touch-free faucet and hi-speed hand dryer for public bathroom use.

Operated by IR sensor. The system includes mounting support for the washbasin, faucet, soap dispenser and hand dryer, available with full brass body or AISI316 material.

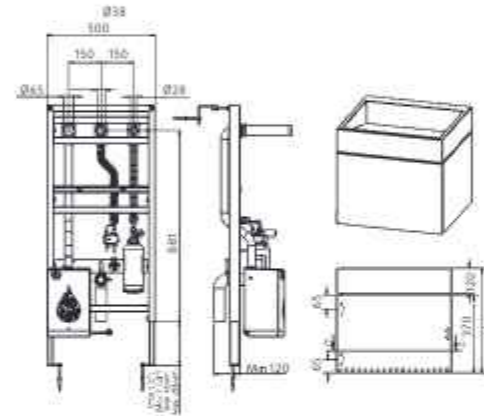

### TUBULAR TRIO DP KE W/BASIN

12V Transformer and power splitter

- 500130 TUBULAR TRIO DP KE W/BASIN

Includes DuPont Corian washbasin and mounting support for the washbasin, faucet, soap dispenser and hand dryer.

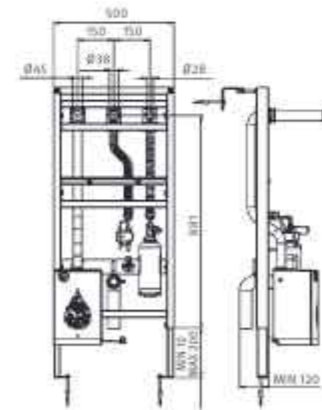

### TUBULAR DP TRIO KE

12V Transformer and power splitter

- 500120 TUBULAR DP TRIO KE

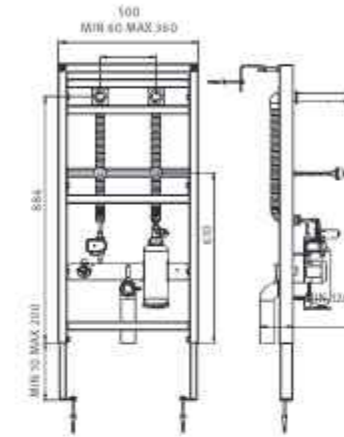

### D28 DP SOAP&WATER KE

12V Transformer and power splitter

- 500100 D28 DP SOAP&WATER KE

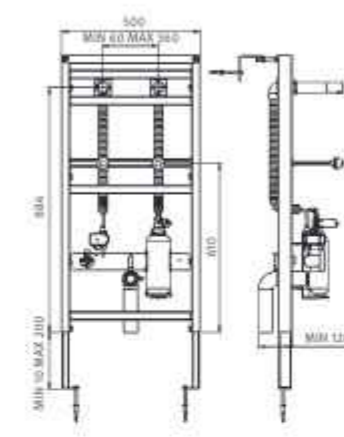

### TUBULAR DP SOAP&WATER KE

12V Transformer and power splitter

- 500200 TUBULAR DP SOAP&WATER KE

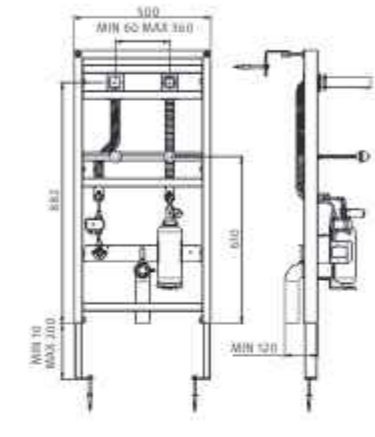

### QUADRAT DP SOAP&WATER KE

12V Transformer and power splitter

- 500400 QUADRAT DP SOAP&WATER KE

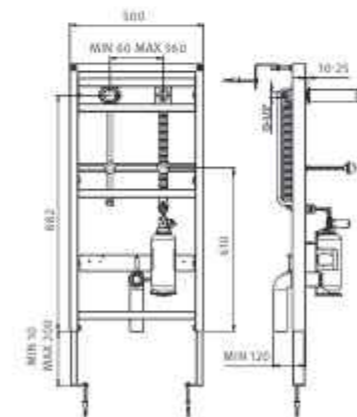

### MALMO 1000 DP SOAP&WATER KE

12V Transformer and power splitter

- 500350 MALMO 1000 DP SOAP&WATER KE

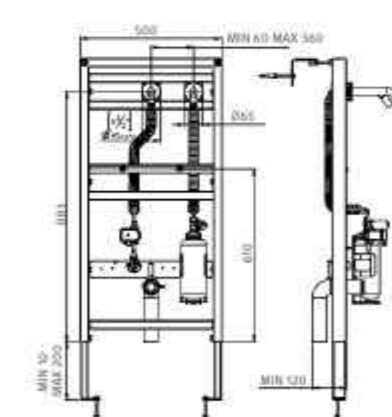

### EXTREME CS SOAP & WATER KE

12V Transformer and power splitter

- 500500 EXTREME CS SOAP & WATER KE,
- 500510 EXTREME CS SOAP & WATER KE AISI316

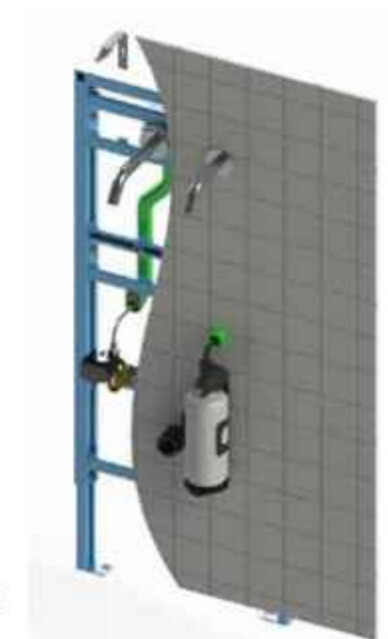

## W.C. FRAME SETS

### Electronic WC Frame Set

Galvanized steel iron frame system for wall hang toilets. For concrete or dry walls with four (4) steel screws. Delivered ready for installation with flush valve and complete required accessories included.  
\* Toilet bowl not included

**Dual flush:** The sensor controls the flushing according to the time the user spends within the sensor range. If the user spends less than one (1) minute within the sensor range a reduced 3 liters flush will take place. If the user spends one (1) minute or more within the sensor range a full 6 liters flush will take place.

**Hygiene Flush:** To maximize hygiene, this product is equipped with a 24 hour duty flush. The flush takes place after 24 hours of non-use. Prevents the trap seal from drying out, possible freezing of pipes and potential bacteria in standing water. This function can be disabled using the remote control.



## W.C. FRAME SETS

### Iron mounting frame set

Galvanized steel iron frame system for wall hang toilets. Delivered ready for installation with flush valve and complete required accessories included. Options for touch or touch-free operation.  
\* Toilet bowl not included

**Hygiene Flush:** To maximize hygiene, this product is equipped with a 24 hour duty flush. The flush takes place after 24 hours of non-use. Prevents the trap seal from drying out, possible freezing of pipes and potential bacteria in standing water. This function can be disabled using the remote control.

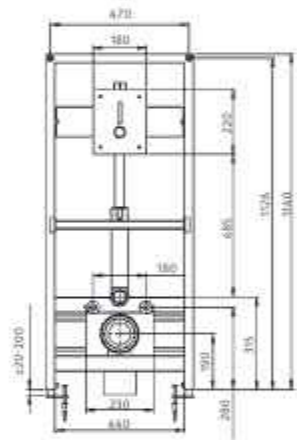

### NOBLE 2032 KE

Dual flush

Features a manual override flush activator button  

- 800320 NOBLE 2032 KE, 9V Transformer

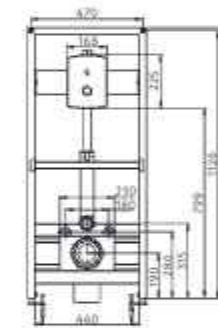

### VENUS COMFORT 2032 K

Dual flush IR system upon request

Features a manual override flush activator button

- 800206 VENUS COMFORT 2032 K, 9V Battery
- 800218 VENUS COMFORT 2032 KE, 9V Transformer

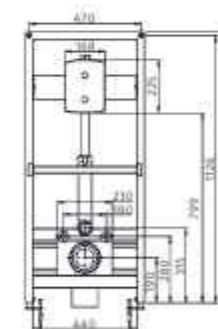

### VENUS COMFORT 2032 DF K

Features two Piezo flush activator switches for each flush volume

- 800221 VENUS COMFORT 2032 DF K, 9V Battery
- 800236 VENUS COMFORT 2032 DF KE, 9V Transformer

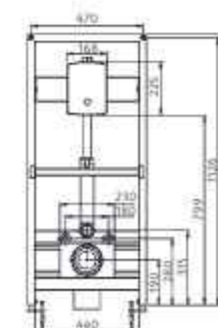

### PERFECT TIME 2032K

Operated by a piezo switch integrated in the panel

- 800286 PERFECT TIME 2032KE, 9V Battery

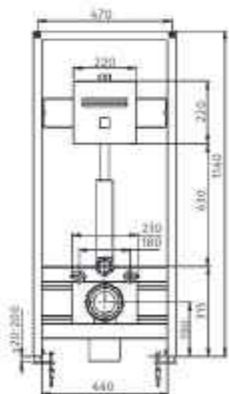

### NARA 2032 K

Dual flush

Features a manual override flush activator button

- 800271 NARA 2032 K, 9V Battery
- 800276 NARA 2032 KE, 9V Transformer



### NARA 2032 PK

Dual flush

Features touch override flush piezo button

- 800287 NARA 2032 PK, 9V Battery
- 800279 NARA 2032 PKE, 9V Transformer

## URINALS FRAME SETS

### Iron mounting frame set

Delivered ready for installation with flush valve and complete required accessories included.

\* Urinal bowl not included



**Hygiene Flush:** To maximize hygiene, this product is equipped with a 24 hour duty flush. The flush takes place after 24 hours of non-use. Prevents the trap seal from drying out, possible freezing of pipes and potential bacteria in standing water. This function can be disabled using the remote control.

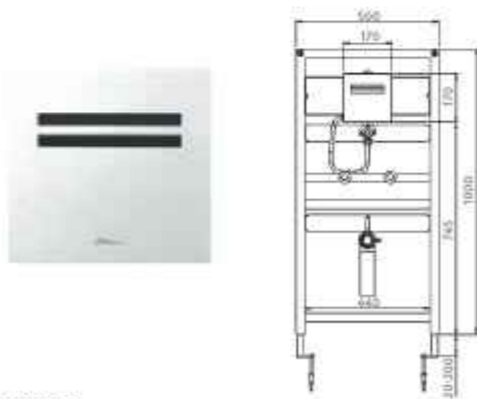

### NARA 2030 K

- 800277 NARA 2030 K, 9V Battery
- 800278 NARA 2030 KE, 9V Transformer

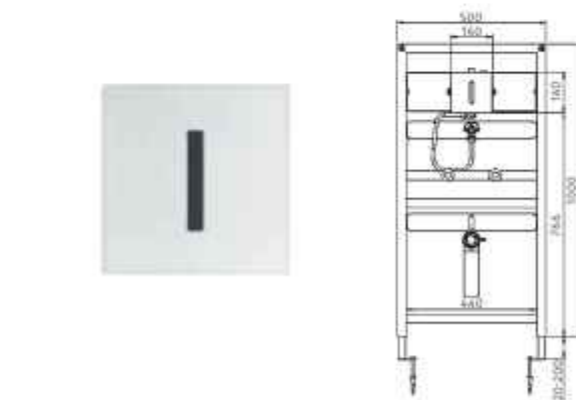

### JUPITER 2040 K

- 800241 JUPITER 2040 K, 9V Battery
- 800251 JUPITER 2040 KE, 9V Transformer

## ARTIS H

### Electronic touch-free concealed cistern system

Complete with an iron frame for wall hung toilet. Activated by a dual flush infrared sensor. Operated by an IP68 encapsulated switching adapter 12V transformer. Includes an override touch piezo switch, and an integral overflow pipe (warning pipe) to prevent flooding. Stainless steel AISI316 panel and 2 vandal resistant side screws, other finishes available. Pre-flush optional upon request. A 24 hour hygiene flush is included. The following settings can be changed by using the Stem remote control: Sensor Range, Security Time, Delay In, Delay Out and On-Off.

**Hygiene Flush:** To maximize hygiene, this product is equipped with a 24 hour duty flush. The flush takes place after 24 hours of non-use. Prevents the trap seal from drying out, possible freezing of pipes and potential bacteria in standing water. This function can be disabled using the remote control.

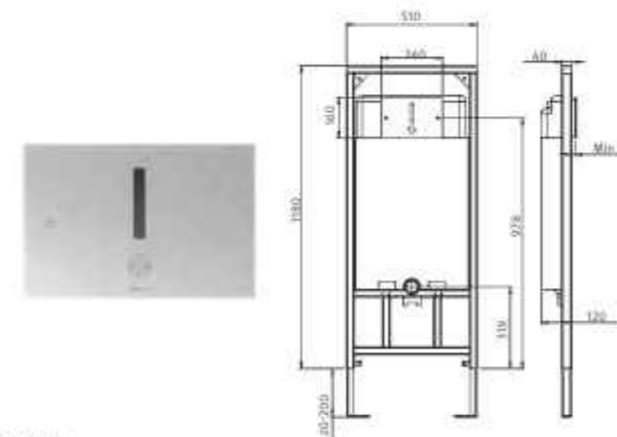

### ARTIS H

- Dual flush operation.  
Includes an override touch piezo switch.
- 800420 ARTIS H, 9V Transformer



## COMPONENTS & ACCESSORIES

	REMOTE CONTROLS	143		IP68 ENCAPSULATED SWITCHING TRANSFORMERS FOR CISTERNS	148
	MIXING VALVES	144		TRANSFORMERS FOR SOAP DISPENSERS	148
	COVER PLATE	145		POWER SPLITTERS	149
	SOLENOID KEY	145		CABLE EXTENSIONS	149
	UNIVERSAL PROPRIETARY SOAP ADAPTORS	146		JUNCTION BOXES	150
	DEFAULT TRANSFORMERS FOR FAUCETS, URINALS, TOILETS AND SHOWERS	147		BATTERY BOXES	150
	IP68 ENCAPSULATED TRANSFORMERS FOR FAUCETS, URINALS, TOILETS AND SHOWERS FOR WET AREAS	147			

## REMOTE CONTROLS

### REMOTE CONTROL

Allows easy maintenance of extensive installations requiring custom settings. The remote control allows adjustment of sensor features for all Stern electronic products, while some functions require a compatible product model:

- Sensor range
- Entrance to the self adjustment mode
- Security time
- Short flow time
- Flow time
- Delay in
- Delay out
- 24 hour hygiene flush
- Lock out time
- Temporary off
- Reset

Code Number: 07100005



### SOAP & WATER REMOTE CONTROL

In addition to the possibility to change settings at liquid or foam soap dispensers, this remote control allows to change settings at Stern matching touch free faucets. The following functions and settings can be changed:

- Sensor range
- Soap quantity in foam Soap Dispensers
- Entrance to the self-adjusting mode in wall mounted faucets
- Soap tank refill
- Temporary shut off
- Air quantity in foam soap dispensers
- Reset to factory settings
- Liquid Soap Quantity 1 - 4

Code Number: 07100014

### LIQUID SOAP DISPENSERS REMOTE CONTROL



- Adjustable settings:**
- Soap dosage
  - Temporary shutoff function
  - Soap tank refill
  - Reset to factory settings

Code Number: 07100008

### FOAM SOAP DISPENSERS REMOTE CONTROL



- Adjustable settings:**
- Soap dosage
  - Air quantity
  - Temporary shutoff function
  - Soap tank refill
  - Reset to factory settings

Code Number: 07100009

## UNDERBASIN TMV THERMOSTATIC MIXING VALVE

### Advantages:

- Easy installation, connects directly to angle valves under the basin
- Thermostatic control for optimum temperature
- Can connect up to 4 faucets simultaneously
- Includes hot water stop function to prevent scalding
- Built-in filters to prevent dirt entering the system
- Back check valves prevent hot water entering cold water inlet

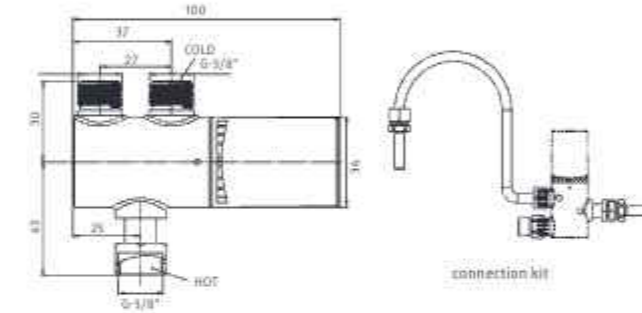

### UNDERBASIN TMV

G 3/8" Inlet

- 07200069 UNDERBASIN TMV, (without connection kit) 1 unit
- 07200069-US UNDERBASIN TMV, (with connection for US) 1 unit
- 07200075 UNDERBASIN TMV, (without connection kit) 12 units
- 07200073 UNDERBASIN TMV, (with connection for US) 12 units

- 07291113 UNDERBASIN TMV CONNECTION KIT, Includes 1 x flexible hose 3/8", 1 x 90° brass arch, 1 x T-piece 3/8"



### INTEGRATED THERMOSTATIC MIXING VALVE

G · 1/2" Inlet

- Includes built in filters and check valves.
- Easy installation
- Thermostatic control for optimum temperature
- For 1 to 6 sanitary points of use (depending on flow rate)

- 07010198 INTEGRATED THERMOSTATIC MIXING VALVE
- 07201001 INTEGRATED THERMOSTATIC MIXING VALVE 6-PACK



### STERN MIXING VALVE

Mechanical Mixing Valve Includes built in filters and check valves.

- Easy installation
- An easy-to-use adjustment allowing pre-mix of hot and cold water.
- Enables the technical staff to manually set the water temperature at any given time.

- 200060 STERN MIXING VALVE 3/8", G · 3/8" Inlet
- 200065 STERN MIXING VALVE 3/8" WITH NUT, G · 3/8" Inlet
- 200070 STERN MIXING VALVE 1/2", G · 1/2" Inlet

## COVER PLATE KIT

Offers a solution for deck mounted faucets to cover unused mounting holes. 28 mm / 4" deck plate kit.

- One hole cover plate, for single hole mount faucets.
- Covers 28 mm diameter / 4" mounting holes
- Complete kit with gasket and screw

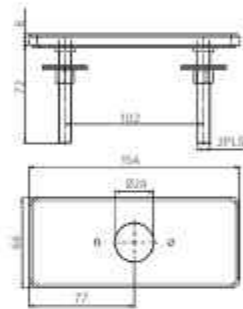
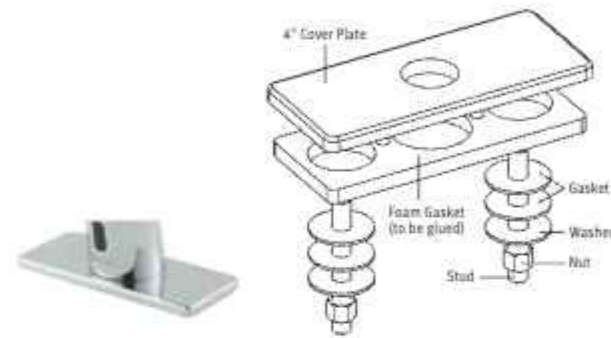

07270290  
COVER PLATE 4"  
ANTI-ROTATION KIT  
FOR CLASSIC CS

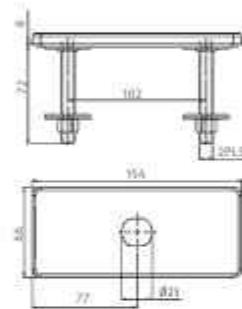

07270288  
COVER PLATE 4"  
ANTI-ROTATION KIT  
FOR CSABA

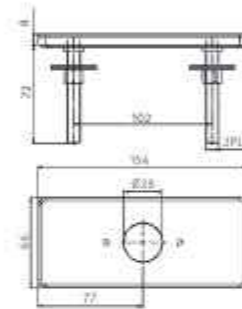

07275005  
COVER PLATE 4"  
ANTI-ROTATION KIT  
FOR EASY 1000

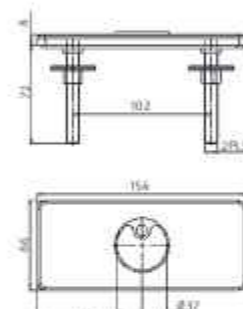

07270291  
COVER PLATE 4"  
ANTI-ROTATION KIT  
FOR TRENDY/EXTREME

## SOLENOID KEY



Specially designed custom key for easy maintenance of the Stern solenoid valves.

Code Number: 07590009

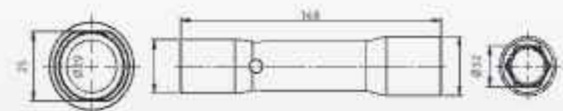

**NEW!**

## PROPRIETARY SOAP ADAPTOR KITS

Now you can connect any container of soap that is compatible with Stern's soap dispenser using our Universal Proprietary Soap Adaptors. Adaptors come in two sizes: 45 - 59 mm, and 30 - 38 mm to easily connect any soap container.



DRAWING	PRODUCT NAME	DESCRIPTION	PART NUMBER
	2L UNDERBASIN TANK CONVERSION KIT	Includes: 2L soap container, breathe pipe, rubber seals and mounting support. To be used with Stern soap dispenser models.	07247011
	SMALL PROPRIETARY SOAP ADAPTOR	Includes: small elastic cover adaptor for use with proprietary individual soap containers. Soap container opening outer min/max diameters including thread: 30mm-38mm	07270294
	SMALL PROPRIETARY SOAP ADAPTOR FOR MF	Includes: small elastic cover adaptor for use with proprietary soap containers. For multifeed up to 3 products. Soap container opening outer min/max diameters including thread: 30mm-38mm	07270295
	BIG PROPRIETARY SOAP ADAPTOR	Includes: big elastic cover adaptor for use with proprietary individual soap containers. Soap container opening outer min/max diameters including thread: 45mm-59mm	07270296
	BIG PROPRIETARY SOAP ADAPTOR FOR MF	Includes: big elastic cover adaptor for use with proprietary soap containers. For multifeed up to 3 products. Soap container opening outer min/max diameters including thread: 45mm-59mm	07270297

## PLUG IN TRANSFORMERS FOR FAUCETS, URINALS, TOILETS AND SHOWERS

Transformers with 5 meter cable male/female waterproof connector (CE, RoHS, UL).

TECHNICAL CHARACTERISTICS	
INPUT VOLTAGE	100 - 240V
OUTPUT VOLTAGE	9V
FREQUENCY	50 - 60 HZ
OUTPUT CURRENT	500 mA

PICTURE	PRODUCT NAME	CONNECTOR	CODE NUMBER	12-PACK CODE
	SWITCHING TRANSFORMER EU	MALE	06522091	06540002
		FEMALE	06522094	06540003
	SWITCHING TRANSFORMER UK	MALE	06522088	06540004
		FEMALE	06522093	06540005
	SWITCHING TRANSFORMER US	MALE	06522115	06540006
		FEMALE	06522116	06540007
	SWITCHING TRANSFORMER AU	MALE	06522089	06540008
		FEMALE	06522095	06540009

## IP68 SWITCHING TRANSFORMERS FOR FAUCETS, URINALS, TOILETS AND SHOWERS

IP68 Switching transformer for wet areas with 5m cable and male/female waterproof connector (CE, RoHS, CB).

PICTURE	PRODUCT NAME	CONNECTOR	INPUT VOLTAGE	OUTPUT VOLTAGE	FREQUENCY	OUTPUT CURRENT	CODE NUMBER
	IP68 SWITCHING NO PLUG	MALE	110-240V	9V	50/60 Hz	600 mA	06522171
		FEMALE					06522172
	IP68 SWITCHING EU	MALE	110-240V	9V	50/60 Hz	600 mA	06522168
		FEMALE					06522169
	IP68 SWITCHING UK	MALE	110-240V	9V	50/60 Hz	600 mA	06522165
		FEMALE					06522166
	IP68 SWITCHING US	MALE	110-240V	9V	50/60 Hz	300 mA	06522099
		FEMALE					06522100
	IP68 SWITCHING AU	MALE	110-240V	9V	50/60 Hz	300 mA	06522103
		FEMALE					06522104

## IP68 ENCAPSULATED SWITCHING TRANSFORMER FOR CISTERNS

IP68 Encapsulated switching transformer with 5 meter cable and male/female waterproof connector (CE, RoHS, UL). Suitable for multiple products installation with electrical connection when combined with the appropriate power splitter. See page 149.



PRODUCT NAME	CONNECTOR	INPUT VOLTAGE	OUTPUT VOLTAGE	FREQUENCY	OUTPUT CURRENT	CODE NUMBER
IP68 ENCAPSULATED SWITCHING TRANSFORMER EU PLUG FOR CISTERNS	MALE	110-240V	12V	50/60 HZ	2.5 A	06522077
	FEMALE					06522078
IP68 ENCAPSULATED SWITCHING TRANSFORMER UK PLUG FOR CISTERNS	MALE	110-240V	12V	50/60 HZ	2.5 A	06522071
	FEMALE					06522072
IP68 ENCAPSULATED SWITCHING TRANSFORMER US PLUG FOR CISTERNS	MALE	110-240V	12V	50/60 HZ	2.5 A	N/A
	FEMALE					N/A







## TRANSFORMERS FOR SOAP DISPENSERS

12V switching adaptor with 5 meter cable and male waterproof connector.

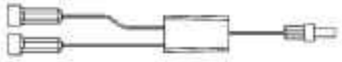
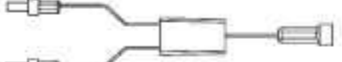

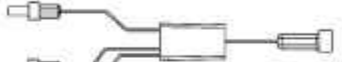



PICTURE	PRODUCT NAME	INPUT VOLTAGE	OUTPUT VOLTAGE	FREQUENCY	OUTPUT CURRENT	CODE NUMBER
	12V TRANSFORMER - UNIVERSAL INCLUDES PLUGS FOR EU, US AND UK	110-240V	12V	50/60 Hz	500 mA	06522082
	12V TRANSFORMER - EU	110-240V	12V	50/60 Hz	500 mA	06522081
	12V TRANSFORMER - USA	110-240V	12V	50/60 Hz	500 mA	06522117
	12V TRANSFORMER - AU	110-240V	12V	50/60 Hz	500 mA	06522085
	12V TRANSFORMER - UK	110-240V	12V	50/60 Hz	500 mA	06522086



## POWER SPLITTERS

DRAWING	PRODUCT NAME	MODEL FEATURES	CODE NUMBER
	POWER SPLITTER 2 WAYS F-M2	Cable length to product: 100 mm Cable length to power supply: 100 mm	06001034
	POWER SPLITTER 2 WAYS M-F2	Cable length to product: 100 mm Cable length to power supply: 100 mm	06001038
	POWER SPLITTER 3 WAYS F-M3	Cable length to product: 100 mm Cable length to power supply: 100 mm	06001036
	POWER SPLITTER 2 WAYS M-F3	Cable length to product: 100 mm Cable length to power supply: 100 mm	06001035
	POWER SPLITTER SOAP & WATER 2 WAYS F-M/F	To be used with 12V transformer. For connection of one soap dispenser and one faucet. Cable length to product: 100 mm. Cable length to power supply: 100 mm	06001025
	POWER SPLITTER SOAP 2 WAYS F-M2	To be used with 12V, 2.5 A transformer. For multiple connection of 2 soap dispensers. Cable length to product: 500 mm. Cable length to power supply: 100 mm	06001026
	POWER SPLITTER SOAP 3 WAYS F-M3	To be used with 12V, 2.5 A transformer. For multiple connection of 3 soap dispensers. Cable length to product: 1X500 mm, 2X1500 mm. Cable length to power supply: 100 mm	06001027
	POWER SPLITTER SOAP 4 WAYS F-M4	To be used with 12V, 2.5 A transformer. For multiple connection of 4 soap dispensers. Cable length to product: 2X500 mm, 2X1500 mm. Cable length to power supply: 100 mm	06001028

## CABLE EXTENSION

DRAWING	PRODUCT NAME	CODE NUMBER
	CABLE EXTENSION 100 MM MALE/FEMALE	06000064
	CABLE EXTENSION 100 MM MALE/MALE	06009018
	CABLE EXTENSION 100 MM FEMALE/FEMALE	06009022
	CABLE EXTENSION 100 MM MALE/FEMALE	06000004
	CABLE EXTENSION 100 MM FEMALE/OPEN	06000003
	CABLE EXTENSION 100 MM MALE/BATTERY	06000029
	CABLE EXTENSION 100 MM FEMALE/BATTERY	06000050

## JUNCTION BOXES

DRAWING	PRODUCT NAME	MODEL FEATURES	INPUT VOLTAGE	OUTPUT VOLTAGE	FREQUENCY	OUTPUT CURRENT	CODE NUMBER
	JUNCTION BOX WITH TRANSFORMER FOR FAUCETS, URINALS, TOILETS AND SHOWERS	Connection point of up to 10 products together. Includes a 12VDC 2 Amp power supply transformer	115-230V	12V	60 HZ	2.1 A	06530013
	JUNCTION BOX WITH TRANSFORMER FOR SOAP DISPENSERS	Connection point of up to 10 Soap Dispensers or 10 ring illuminated products. Includes a 12VDC 4.2 Amp power supply transformer.	115-230V	12V	60 HZ	4.2 A	06530062

### CABLES FOR JUNCTION BOX

DRAWING	PRODUCT NAME	MODEL FEATURES	CODE NUMBER
	OUTPUT CABLE FOR JUNCTION BOX	3 meters male connector	06000084
	OUTPUT CABLE FOR JUNCTION BOX	3 meters female connector	06000086

## BATTERY BOXES

PICTURE	PRODUCT NAME	REQUIRED BATTERIES	CONNECTOR	CODE NUMBER	12-PACK CODE	15-PACK CODE
	IP67 BLACK BATTERY BOX	6x1.5V AA batteries	Male waterproof connector	06530092	N/A	06533002
		6x1.5V AA batteries (Not supplied)		06530096	N/A	06533000
		6x1.5V AA batteries	Female waterproof connector	06530093	N/A	06533003
		6x1.5V AA batteries (Not supplied)		06530091	N/A	06533001
	IP67 9V BLACK BATTERY BOX	9V Battery (Alkaline or Lithium - Not supplied)	Male waterproof connector	06530080	N/A	N/A
			Female waterproof connector	06530089	N/A	N/A
	BATTERY BOX FOR SOAP DISPENSERS	6xD batteries (Not supplied)	Male waterproof connector	06530041	N/A	N/A

# ALPHABETIC INDEX

PRODUCT	PN	PAGE	PRODUCT	PN	PAGE
2L underbasin tank conversion kit	07247011	146	Classic AB 1953	291010	23
12V transformer - AU	06522085	148	Classic 1000 AB 1953	292020	23
12V transformer - EU	06522081	148	Classic 1000 B AB 1953	292120	23
12V transformer - Universal	06522082	148	Classic 1000 E AB 1953	292230	23
12V transformer - USA	06522080	148	Classic B AB 1953	291110	23
12V transformer - UK	06522086	148	Classic E AB 1953	291210	23
Adjustment arm for C57(verB)	07120348	126	Classic CS B	293100	23
Apollo ALB	340600	40	Classic CS E	293200	23
Apollo ALE	340700	40	Classic Foam E	292300	62
Apollo Free	340100	43	Classic Soap Dispenser B	292400	62
Apollo Medical B	314500	41	Classic Soap Dispenser E	292410	62
Apollo Medical E	314510	41	Classic Foam E 6-pack	292300	62
Apollo Medical FB	314530	41	Classic SD B 6-pack	250921	62
Apollo Medical FE	314540	41	Classic SD E 6-pack	250911	62
APS Kit for faucet	07225008	44	Classic SD 1.6 E	292416	62
APS kit for Toilet	07225018	124	Condor	210000	26
APS Threaded rod Kit shower	07226054	110	Condor 1010	210100	26
Artis H	800420	140	Condor 1010 E	210300	26
Battery box for soap dispensers	06530041	150	Condor E	210200	26
Below Deck Multifeed kit	07220096	75	Cool TFB	280150	28
Below Deck Multifeed kit with lockable cabinet	07220096CB	75	Cool TFE	280140	28
Boreal B	212000	8	Cool TF GB	280160	28
Boreal E	212005	8	Cool TF GE	280170	28
Boreal Plus B	212010	8	Cover Plates	-	145
Boreal Plus E	212015	8	Csaba 2-in-1	233013	6
Boreal 1000 B	212050	8	Csaba B	233000	7
Boreal 1000 E	212055	8	Csaba E	233010	7
Boreal 1000 Plus B	212060	8	Csaba 1000 B	233020	7
Boreal 1000 Plus E	212065	8	Csaba 1000 E	233030	7
Boreal Foam Dispenser E	212130	52	Csaba Petite B	233042	7
Boreal FD E 6-PACK	212131	52	Csaba Petite E	233040	7
Boreal Soap Dispenser B	212100	52	Csaba Plus B	233050	7
Boreal Soap Dispenser E	212105	52	Csaba Plus E	233051	7
Boreal SD B 6-pack	212101	52	Csaba Soap Dispenser B	233110	49
Boreal SD E 6-pack	212106	52	Csaba Soap Dispenser E	233100	49
boreal SD plus B	212110	52	Csaba SD B 6-PACK	233111	49
BOREAL SD PLUS E	212115	52	Csaba SD E 6-PACK	233101	49
Boreal SD plus B 6-PACK	212111	52	Csaba SD 1.6 E	233102	49
Boreal SD plus E 6-PACK	212116	52	Csaba SD Plus B	233114	49
BTM SD CS B	280225	92	Csaba SD Plus E	233106	49
BTM SD CS E	280220	92	Csaba SD Plus B 6-PACK	233115	49
BTM soap dispenser B	280210	92	Csaba SD Plus E 6-PACK	233107	49
BTM soap dispenser E	280200	92	Csaba Soap Dispenser E with level indicator	233105	50
BTM Foam E	280250	92	D28 B	352000	33
BTM Faucet E	280300	91	D28 B AISI316	352130	33
BTM Faucet B	280310	91	D28 DP Soap&Water KE	500100	135
Cable extension 100 mm female/battery	06000050	149	D28 Dual Power B	352300	33
Cable extension 100 mm female/female	06009022	149	D28 Dual Power B AISI316	352301	33
Cable extension 100 mm female/open	06000003	149	D28 Dual Power E	352400	33
Cable extension 100 mm male/battery	06000029	149	D28 Dual Power E AISI316	352401	33
Cable extension 100 mm male/female	06000064	149	D28 E	352100	33
Cable extension 100 mm male/open	06000004	149	D28 E AISI316	352120	33
Cable extension 100 mm male/male	06009018	149	D28 LB	352010	33
			D28 LE	352110	33

D28 LB AISI316	352015	33
D28 LE AISI316	352125	33
D28 DP LB AISI316	352304	33
D28 DP LE AISI316	352403	33
D28 DUAL POWER LB	352303	33
D28 DUAL POWER LE	352410	33
DF El. Cistern Valve w/override	07140067	126
Dolphin 1000 FB	270320	27
Dolphin 1000 FE	270330	27
Dolphin FB	270170	27
Dolphin FE	270180	27
Dolphin GB	270120	27
Dolphin GE	270220	27
Easy 1000 B	246050	24
Easy 1000 E	246060	24
Easy B	246010	24
Easy E	246020	24
Electromagnetic SF cistern	620620	126
Electromagnetic DF cistern	620630	126
Elite 1000 B	236700	17
Elite 1000 B with technician's mixer	236720	18
Elite 1000 E	236800	17
Elite 1000 E AISI316	236803	17
Elite 1000 E with technician's mixer	236805	18
Elite 1000 LB	236550	17
Elite 1000 LE	236650	17
Elite 1000 Plus B	236750	18
Elite 1000 Plus E	236850	18
Elite 1000 Plus E AISI316	236453	18
Elite SD 1.6 E	236216	59
Elite SD 1.6 E AISI316	236126	60
Elite B	236300	17
Elite E	236400	17
Elite E AISI316	236404	17
Elite foam E	236120	59
Elite foam 6-pack E	236121	59
Elite foam 6-pack E AISI316	236123	60
Elite foam E	236120	59
Elite foam E AISI316	236120	60
Elite LB	236500	17
Elite LE	236600	17
Elite Plus B	236350	18
Elite Plus E	236450	18
Elite SD 6-pack B	236111	59
Elite SD 6-pack B AISI316	236114	60
Elite SD 6-pack E	236101	59
Elite SD 6-pack E AISI316	236117	60
Elite SD Plus B AISI316	236108	60
Elite SD Plus E AISI316	236106	60
Elite soap dispenser B	236110	59
Elite soap dispenser B AISI316	236113	60
Elite soap dispenser E	236100	59
Elite soap dispenser E AISI316	236103	60
Elite soap dispenser plus B	236107	59

Elite SD Plus B 6-Pack	236108	59
Elite soap dispenser plus B AISI316	236109	60
Elite soap dispenser plus E	236105	59
Elite SD Plus E 6-Pack	236106	59
Elite soap dispenser plus E AISI316	236104	60
Elite Soap Dispenser E with level indicator	236131	61
Ever HD	230510	93
Ever HD AISI316	230520	93
Extension kit Apollo AL	07240060	40
Extension kit for wave/prox sensor	07240061	40
Extreme 1000 Plus B	237150	13
Extreme 1000 Plus E	237050	13
Extreme 1000B	237100	13
Extreme 1000 BRE	237005	14
Extreme 1000E	237000	13
Extreme 1000 LFB	237102	15
Extreme 1000 LFE	237003	15
Extreme 1000 LFB AISI316	237103	15
Extreme 1000 LFE AISI316	237004	15
Extreme B	237200	13
Extreme BRE	237305	14
Extreme CS B	237801	31
Extreme CS B AISI316	237801-316	31
Extreme CS E	237800	31
Extreme CS E AISI316	237800-316	31
Extreme CS DPB	237802	31
Extreme CS DPB AISI316	237802-316	31
Extreme CS DPE	237803	31
Extreme CS DPE AISI316	237803-316	31
Extreme CS 1000B	237720	31
Extreme CS 1000E	237710	31
Extreme CS 1000B AISI316	237715	31
Extreme CS 1000E AISI316	237725	31
Extreme CS soap dispenser B	237891	69
Extreme CS SD 2030 B	237896	70
Extreme CS SD 1.6 E	237882	69
Extreme CS Soap & water KE	500500	136
Extreme CS Soap & water KE AISI316	500510	136
Extreme CS soap dispenser B AISI316	237891-316	70
Extreme CS SD 2030 B AISI316	237896-316	70
Extreme CS soap dispenser E	237890	69
Extreme CS SD 2030 E	2378926	69
Extreme CS 2030 SD 1.6 E	237884	69
Extreme CS soap dispenser E AISI316	237890-316	70
Extreme CS SD 2030 E AISI316	237892-316	69
Extreme CS SD B 6-pack	237894	69
Extreme CS SD 2030 B 6-pack	237897	69
Extreme CS SD E 6-pack	237893	69
Extreme CS SD 2030 E 6-pack	237895	69
Extreme CS SD B AISI316 6-pack	237898	70
Extreme CS SD AISI316 1.6 E	237885	70
Extreme CS SD 2030 B AISI316 6-pack	237880	70
Extreme CS SD E AISI316 6-pack	237899	70
Extreme CS SD 2030 E AISI316 6-pack	237881	70

Extreme CS 2030 SD AISI316 1.6 E	237883	70
Extreme E	237300	13
Extreme FW	237709	112
Extreme HLB	237317	14
Extreme HLE	237316	14
Extreme HLB LF	237340	14
Extreme HLE LF	237341	14
Extreme Plus B	237250	13
Extreme Plus E	237350	13
Extreme LFB	237820	15
Extreme LFB AISI316	237821	15
Extreme LFE	237810	15
Extreme LFE AISI316	237811	15
Extreme Petite CS E	237818	112
Extreme Petite CS DPE	237840	112
Extreme Petite CS dpE AISI316	237819	112
Extreme SD 1.6 E	237916	57
Extreme soap dispenser B	237920	57
Extreme SD B 6-pack	237921	57
Extreme soap dispenser E	237900	57
Extreme SD B 6-pack	237921	57
Extreme SD E 6-pack	237901	57
Extreme SD plus B 6-pack	237923	57
Extreme SD plus E 6-pack	237906	57
Extreme soap dispenser plus B	237922	57
Extreme soap dispenser plus E	237905	57
Extreme Soap Dispenser E with level Indicator	237917	58
Foot washfree	113730	111
Foot Washfree 3000	113720	111
Free	113100	130
Free E	113200	130
Free SP	800504	130
Green AB 1953	225901	21
Green 1000 AB 1953	225801	21
Green 1000 B AB 1953	225871	21
Green 1000 BRE AB 1953	225891	21
Green 1000 E AB 1953	225821	21
Green 28 foam E	352920	64
Green 28 foam 6-pack	352921	64
Green 28 SD B 6-pack	352901	64
Green 28 SD E 6-pack	352911	64
Green 28 soap dispenser B	352900	64
Green 28 soap dispenser E	352910	64
Green 28 SD 1.6 E	352916	64
Green B AB 1953	225951	21
Green BRE AB 1953	225921	21
Green E AB 1953	225941	21
Green foam E	225842	63
Green foam E 6-pack	225843	63
Green SD B 6-pack	225846	63
Green SD E 6-pack	225841	63
Green SD 1.6 E	225816	63
Green soap dispenser B	225845	63
Green soap dispenser E	225840	63

Integrated thermostatic mixing valve	07010198	144
Integrated thermostatic mixing valve 6-pack	07201001	144
IP67 9V Black battery box female connector	06530080	150
IP67 9V Black battery box male connector	06530089	150
IP67 Black battery box female connector (without batteries)	06530091	150
IP67 Black battery box female connector	06530093	150
IP67 Black battery box male connector (without batteries)	06530083	150
IP67 Black battery box male connector	06530092	150
IP68 Switching transformer no plug male connector	06522065	147
IP68 Encap.Switch 13.5V/2.5A Transformer EU-M	06522142	126
IP68 Switching transformer no plug female connector	06522070	147
IP68 Switching transformer EU male connector	06522097	147
IP68 Switching transformer EU female connector	06522098	147
IP68 Switching transformer UK male connector	06522101	147
IP68 Switching transformer UK female connector	06522102	147
IP68 Switching transformer US male connector	06522099	147
IP68 Switching transformer US female connector	06522100	147
IP68 Switching transformer AU male connector	06522103	147
IP68 Switching transformer AU female connector	06522104	147
IP68 Encapsulated switching transformer eu plug for cisterns female connector	06522078	148
IP68 Encapsulated switching transformer EU plug for cisterns male connector	06522077	148
IP68 Encapsulated switching transformer UK plug for cisterns female connector	06522072	148
IP68 Encapsulated switching transformer UK plug for cisterns male connector	06522071	148
Junction box with transformer for faucets, urinals, toilets and showers	06530013	150
Junction box with transformer for soap dispensers	06530062	150
Jupiter 1011	132100	129
Jupiter 1032	134510	129
Jupiter 1032 E	134520	129
Jupiter 2040	125900	127
Jupiter 2040 E	125901	127
Jupiter 2040 H	125910	127
Jupiter 2040 HE	125911	127
Jupiter 2040 K	800241	139
Jupiter 2040 KE	800251	139
Jupiter 3002 EM	140315	131
Jupiter 3002 M	140215	131
Jupiter M 0.5 GPF	140112	131
Jupiter ME 0.5 GPF	140516	131
Long bracket 200 mm (Washfree 1000)	07055175	43
Lotus Topfill E	230850	53
Lotus Topfill FE	230860	53
Malmo	225865	32
Malmo 1000	225860	32
Malmo 1000	225861	32
Malmo 1000 DP Soap&Water KE	500350	136
Medical 1000 TE	314600	41
MF Behind mirror SD	07292223	92
MF BTM Foam	07292270	92

MF Classic Foam Dispenser	07292207	62
MF Classic soap Dispenser	07292177	62
MF Csaba soap Dispenser	07292288	49
MF Elite Foam Dispenser	07292205	59
MF Elite SD Plus	07292093	59
MF Elite Soap Dispenser	07292077	59
MF Elite Foam Dispenser AISI316	07292240	60
MF Elite SD Plus AISI316	07292241	60
MF Elite Soap Dispenser AISI316	07292239	60
MF Extreme Plus Soap Dispenser	07292095	57
MF Extreme Soap Dispenser	07292056	57
MF Extreme CS SD E	07292271	69
MF Extreme CS Soap Dispenser 2030	07292290	69
MF Extreme CS SD E AISI316	07292285	70
MF Extreme CS Soap Dispenser 2030 AISI316	07292286	70
MF Green 28 Foam Dispenser	07292206	64
MF Green 28 Soap Dispenser	07292155	64
MF Green Foam Dispenser	07292228	63
MF Green Soap Dispenser	07292062	63
MF Quadrat 2030 Soap Dispenser	07292094	72
MF Quadrat Soap Dispenser	07292078	71
MF Trendy Foam Dispenser	07292183	55
MF Trendy Plus Soap Dispenser	07292099	55
MF Trendy Soap Dispenser	07292073	55
MF Tubular Soap Dispenser 2030	07292081	66
MF Tubular Foam Dispenser	07292186	65
MF Tubular Soap Dispenser	07292076	65
MF Tubular Foam Dispenser AISI316	07292231	67
MF Tubular Soap Dispenser AISI316	07292221	67
MF Tubular 2030 Soap Dispenser AISI316	07292222	68
Nara 2022	160750	118
Nara 2022 E	160700	118
Nara 2030	170200	128
Nara 2030 E	170100	128
Nara 2030 K	800277	139
Nara 2030 KE	800278	139
Nara 2032	160310	117
Nara 2032 E	160410	117
Nara 2032 K	800271	137
Nara 2032 KE	800276	137
Nara 2032 P	160610	117
Nara 2032 PE	160510	117
Nara 2032 PK	800287	137
Nara 2032 PKE	800279	137
Nara ECO 2032	160320	117
Nara ECO 2032 E	160330	117
Nara ECO 2032 PE	160340	117
Nara Q	360510	39
Nara QE	360500	39
Neptune 1032	613200	109
Neptune 1032 E	613400	109
Neptune 1042 T	612280	104
Neptune 1042 TE	612281	104
Neptune Medical 1000 T	610250	106

Neptune Medical 1000 T Bottom outlet	610255	106
Neptune shower panel 1000 TB	602410	100
Neptune shower panel 1000 TE	604410	100
Neptune shower panel B	601410	100
Neptune shower panel E	603410	100
Noble 2032	460640	115
Noble 2032 E	460600	115
Noble 2032 P	460630	115
Noble 2032 PE	460610	115
Noble 2032 KE	800320	137
Noble 3032 P	460720	116
Noble 3032 PE	460730	116
Noble 3032	460700	116
Noble 3032 E	460710	116
Output cable for junction box	06000084	150
Output cable for junction box	06000086	150
Paper Towel holder	03300148	91
Perfect time SH 1032	613700	109
Perfect time SH 1032 E	613800	109
Perfect time 1042 T	612253	105
Perfect time 1042 TE	612254	105
Perfect time 2032 E	410761	121
Perfect time 2032KE	800286	138
Perfect time SH control assembly WPC	07040312	110
Perfect Time shower panel 1000 TB	602400	101
Perfect Time shower panel 1000 TB w/ hand shower	602401	101
Perfect Time shower panel 1000 TE	604400	101
Perfect Time shower panel 1000 TE w/ hand shower	604401	101
Perfect Time shower panel B	601400	101
Perfect Time shower panel E	603400	101
Perfect Time shower panel LB	601402	101
Perfect Time shower panel M	607200	103
Perfect Time shower panel TM	607100	103
Piezo kit for W.C. with distant control	07226042	123
Power splitter 2 ways F-M2	06001034	149
Power splitter 2 ways M-F2	06001038	149
Power splitter 2 ways M-F3	06001035	149
Power splitter 3 ways F-M3	06001036	149
Power splitter soap & water 2 ways F-M2	06001025	149
Power splitter soap 2 ways F-M2	06001026	149
Power splitter soap 3 ways F-M3	06001027	149
Power splitter soap 4 ways F-M4	06001028	149
PPS high security kit for shower	07226033	110
Programmable piezo kit for shower	07225019	110
Programmable piezo kit for beach shower columns	07226050	110
Proprietary Soap Adaptor kits	-	77
Proprietary Soap Adaptor kits - componenets	-	146
Prox & wave sensor kit for toilet	620100	125
Prox kit for toilet	620100	124
Prox Kit for faucet	620200	44
Prox Kit for faucet with detachable body for faucet	620200	44
Prox Kit for shower	620000	110
Prox Kit for Urinal	620700	132
Prox kit front fixation for urinal	620750	132

Quadrat 1000 DM B	351500	16
Quadrat 1000 DM E	351510	16
Quadrat 2030 B	351300	38
Quadrat 2030 E	351400	38
Quadrat 2030 LB	351305	38
Quadrat 2030 LE	351405	38
Quadrat 2030 SD 1.6 E	351316	72
Quadrat 2030 soap dispenser B 6-pack	351921	72
Quadrat 2030 soap dispenser E 6-pack	351931	72
Quadrat B	351100	38
Quadrat E	351200	38
Quadrat DM B	351020	16
Quadrat DM E	351010	16
Quadrat DM SD B	351950	54
Quadrat DM SD B 6-pack	351951	54
Quadrat DM SD E	351952	54
Quadrat DM SD E 6-pack	351953	54
Quadrat DM FOAM E	351960	54
Quadrat DM FOAM E 6-pack	351961	54
Quadrat DP Soap&Water KE	500400	136
Quadrat LB	351105	38
Quadrat LE	351205	38
Quadrat SD 1.6 E	351916	71
Quadrat soap dispenser 2030 B	351920	72
Quadrat soap dispenser 2030 E	351930	72
Quadrat soap dispenser B	351910	71
Quadrat soap dispenser B 6-pack	351911	71
Quadrat soap dispenser E	351900	71
Quadrat soap dispenser E 6-pack	351901	71
Recessed Mounting Duo	280500	88
Remote Control	07100005	143
Remote control for foam soap dispensers	07100009	143
Remote control for liquid soap dispenser	07100008	143
Remote control for soap & water	07100014	143
SA module	280476	86
Set of pipes	07291037	118
SH 3000	600100	99
SH 9000	600400	99
SH 9020	600420	99
Sleeve Kit for SH 9000	07240046	99
Smart 1000 B	235500	19
Smart 1000 E	235600	19
Smart 1000 LB	235510	19
Smart 1000 LE	235610	19
Smart 1000 Plus B	235550	20
Smart 1000 Plus E	235650	20
Smart B	235100	19
Smart E	235200	19
Smart LB	235110	19
Smart LE	235210	19
Smart Plus B	235150	20
Smart Plus E	235250	20
Smartbox	280222	78
Solenoid Key	07590009	145

Stem mixing valve 1/2"	200070	144
Stem mixing valve 3/8"	200060	144
Stem mixing valve 3/8" with nut	200065	144
SWA Hi-Speed Module	280410	89
SWAR City	280455	84
SWAR Module	280460	85
SWAR P	280470	86
SWAR TV	280461	83
SWA HI-SPEED Module	280410	89
Swan 1000 AB 1953	252210	25
Swan 1000 B AB 1953	252310	25
Swan 1000 E AB 1953	252420	25
Swan 1010 AB 1953	250220	25
Swan 1010 B AB 1953	250310	25
Swan 1010 E AB 1953	250420	25
Switching transformer AU female connector	06522095	147
Switching transformer AU male connector	06522089	147
Switching transformer EU female connector	06522094	147
Switching transformer EU male connector	06522091	147
Switching transformer UK female connector	06522093	147
Switching transformer UK male connector	06522088	147
Switching transformer US female connector	06522092	147
Switching transformer US male connector	06522090	147
Thermix SH 1000 T	610400	108
Top Filling Multifeed Kit	07220090	75
Top Filling Multifeed Kit With lockable cabinet	07220090CB	75
Top Filling Multifeed Kit with Soap Level Indicator	07220152	74
Top Filling Multifeed Kit with Soap Level Indicator With lockable cabinet	07220152CB	74
Touch Free B AB 1953	225610	22
Touch Free E AB 1953	225710	22
Touch SH 1000 T	620710	107
Touch SH 1000 T Bottom outlet	620700	107
Touch Free Hand Sanitizer Pillar	281100	80
Touch Free Hand Sanitizer Stand	281000	79
Touch Free Hand Sanitizer Station	233200	79
Trendy 1000 BRE	239305	10
Trendy 1000 Plus B	239250	10
Trendy 1000 Plus E	239350	10
Trendy 1000B	239200	9
Trendy 1000E	239300	9
Trendy 1000LB	239600	9
Trendy 1000 LE	239700	9
Trendy B	239000	9
Trendy BRE	239105	10
Trendy E	239100	9
Trendy Foam E	239930	55
Trendy Foam E 6-pack	239931	55
Trendy LB	239400	9
Trendy LE	239500	9
Trendy Plus B	239050	10
Trendy Plus E	239150	10
Trendy SD 1.6 E	239916	55
Trendy SD B 6-Pack	239911	55

Trendy SD E 6-Pack	239902	55
Trendy soap dispenser B	239910	55
Trendy soap dispenser E	239900	55
Trendy soap dispenser plus B	239912	55
Trendy soap dispenser plus E	239902	55
Trendy SD Plus B 6-pack	239913	55
Trendy SD Plus E 6-pack	239903	55
Trendy Soap Dispenser with level indicator	239906	56
Trendy TB	236930	11
Trendy TE	236935	11
Tubular 1000 B AB1953	350805	36
Tubular 1000 B Box	350800	36
Tubular 1000 E AB1953	350855	36
Tubular 1000 E Box	350950	36
Tubular 2030 B	350300	35
Tubular 2030 E	350400	35
Tubular 2030 E AISI316	350402	35
Tubular 2030 LB	350310	35
Tubular 2030 LE	350410	35
Tubular 2030 LE AISI316	350412	35
Tubular B	350200	35
Tubular B AISI316	350208	35
Tubular CB	350500	36
Tubular CE	350600	36
Tubular DMB	350700	22
Tubular DME	350750	22
Tubular DP Soap&Water KE	500200	136
Tubular DP Trio KE	500120	135
Tubular E	350100	35
Tubular E AISI316	350109	35
Tubular foam E	350980	65
Tubular foam E AISI316	350982	67
Tubular foam E 6-pack	350980	65
Tubular foam E AISI316 6-pack	350983	67
Tubular LB	350210	35
Tubular LB AISI316	350213	35
Tubular HD	350030	94
Tubular HD AISI316	350040	94
Tubular DP HD	350020	94
Tubular DP HD AISI316	350010	94
Tubular LE	350120	35
Tubular LE AISI316	350124	35
Tubular Perth B	350207	36
Tubular Perth E	350107	36
Tubular SD 2030 B 6-pack	350923	66
Tubular SD 2030 E 6-pack	350928	66
Tubular SD 1.6 E	350116	65
Tubular SD 1.6 E AISI316	350932	67

Tubular SD B 6-pack	350921	65
Tubular SD E 6-pack	350926	65
Tubular 2030 SD 1.6 E	350816	66
Tubular 2030 SD 1.6 E AISI316	350916	68
Tubular SD 2030B AISI316 6-pack	350992	68
Tubular SD 2030E AISI316 6-pack	350933	68
Tubular SD B AISI316 6-pack	350991	67
Tubular SD E AISI316 6-pack	350984	67
Tubular soap dispenser 2030 B	350922	66
Tubular soap dispenser 2030 E	350927	66
Tubular soap dispenser B	350920	65
Tubular soap dispenser E	350925	65
Tubular soap dispenser B AISI316	350919	67
Tubular soap dispenser E AISI316	350924	67
Tubular soap dispenser 2030 B AISI316	350918	68
Tubular soap dispenser 2030 E AISI316	350917	68
Tubular Trio DP KE with basin	500130	135
Tubular wave DP LE	350190	37
Tubular XLB	350215	36
Tubular XLE	350415	36
Tubular XL DPB	350224	36
Tubular XL DPE	350223	36
Underbasin TMV	07200069	144
Underbasin TMV connection kit	07291113	144
Proprietary Soap Adaptor kits	-	146
Venus 1.28 GPF	420242	122
Venus 3002	420255	122
Venus 3002 E	420231	122
Venus 3002 R	420241	122
Venus 3002 RE	420265	122
Venus 3003R PE	420280	122
Venus comfort 2032	410562	120
Venus comfort 2032 DF	410446	121
Venus comfort 2032 DFE	410447	121
Venus Comfort 2032 DF K	800221	138
Venus Comfort 2032 DF KE	800236	138
Venus comfort 2032 E	410541	120
Venus Comfort 2032 K	800206	138
Venus Comfort 2032 KE	800218	138
Venus comfort 2032 P	410576	120
Venus comfort 2032 PE	410546	120
Venus E 1.28 GPF	420232	122
Venus XS 2032 E	410601	120
Washfree 1000	316010	43
Wave Kit for faucet	620400	44
Wave Kit for shower	620810	110
Wave on-off kit for toilet	620600	124
Wave On/Off for Cistern	07224101	126





---

## **STERN ENGINEERING LTD.**

777 Passaic Avenue  
Clifton NJ, 07012  
Tel: +1.973.773.8011

---

86 Lackawanna Ave, Suite 315  
Woodland Park, NJ 07424

---

[info@sternfaucets.com](mailto:info@sternfaucets.com)  
[www.sternfaucets.us](http://www.sternfaucets.us)  
[www.sternfaucets.com](http://www.sternfaucets.com)  
[www.sternfaucets.es](http://www.sternfaucets.es)